

Molecular systematics of Trilliaceae II. Phylogenetic analyses of *Trillium* and its allies using sequences of *rbcL* and *matK* genes of *cpDNA* and internal transcribed spacers of 18S–26S nrDNA

SHAHROKH KAZEMPOUR OSALOO and SHOICHI KAWANO

Department of Botany, Graduate School of Science, Kyoto University, Kyoto 606–8502, Japan

Abstract

Coding regions of the *rbcL* and *matK* genes of *cpDNA* and internal transcribed spacers (ITS) of nuclear ribosomal DNA were sequenced to study phylogenetic relationships within and among all four genera of Trilliaceae: *Trillium*, *Paris*, *Daiswa* and *Kinugasa*. The *rbcL* gene has evolved much slower than *matK* and in particular ITS; hence the phylogenetic trees based on the *rbcL* gene show a much lower resolution than trees based on either *matK* or ITS. The general topology of phylogenetic trees resulting from separate parsimony analyses of the *matK* and ITS sequences are relatively congruent, with the exception of the placement of *T. pusillum*. Both *matK* and ITS phylogenies reveal that *T. rivale* diverges at the base of the trees. In both trees, *Paris*, *Daiswa* and *Kinugasa* form a relatively weakly supported group. Within this group, the allo-octaploid *Kinugasa japonica* is the sister group of *Daiswa* species. The *Paris–Daiswa–Kinugasa* group, the major *Trillium* group, and *T. undulatum* and *T. govonianum* showed a loosely related topology, but their affinities are not evident according to these two molecular markers. However, phylogenetic analysis of amino acid sequences derived from *matK* shows that *T. rivale* together with clades *T. undulatum–T. govonianum*, *Daiswa–Kinugasa* and *Paris* is basally diverged as a sister group to the remainder of *Trillium*.

Keywords: amino acid tree, *Daiswa*, internal transcribed spacers, *Kinugasa*, *matK*, *Paris*, phylogeny, *rbcL*, *Trillium*, Trilliaceae.

Received 1 November 1998; revision received 15 December 1998; accepted 20 December 1998

Society for the Study of Plant Species Biology

Introduction

According to the most current classifications (Takhtajan 1980, 1987, 1997; Thorne 1992), the family Trilliaceae comprises the genera *Trillium* L. and *Paris* L. *sensu lato* (or *Paris sensu stricto* plus segregates *Daiswa* Raf. and *Kinugasa* Tatewaki and Suto). Besides these genera, the family has also included *Medeola* L. and *Scoliopus* Torrey (Hutchinson 1973). Evidence from various standpoints, including gross morphology, embryology (Berg 1959, 1962a,b), anatomy (Utech 1978, 1979, 1992), palynology (Takahashi 1984), karyology (Sen 1975; Tamura 1995), and molecular systematics (Kato *et al.* 1995b), however, does

not at all support a close relationship of either *Medeola* or *Scoliopus* with the Trilliaceae.

Morphologically, the Trilliaceae is characterized by a simple stem terminating in a relatively large, solitary flower subtended by a single whorl of net-veined leaves. The family comprises 2x, 3x, 4x, 6x, and 8x plants, with a morphologically similar basic complement of five chromosomes ($x=5$) that are unusually large. The monophyly of the family therefore is supported karyologically (Haga 1934; Sen 1975; Tamura 1995).

As a segregate family, the Trilliaceae has been placed in the Liliales (Hutchinson 1973; Thorne 1983, 1992; Kubitzki *et al.* 1998) or in the Smilacales (Takhtajan 1980), the Dioscoreales (Dahlgren *et al.* 1985; Takhtajan 1987) or in a monotypic order Trilliales (Takhtajan 1997). Recent cladis-

Correspondence: Shoichi Kawano.

tic analyses of morphological and molecular characters do not corroborate the phylogenetic placement of the Trilliaceae. The analysis of morphological characters indicates that the Trilliaceae is a sister to Smilacaceae in Liliales (Goldblatt 1995) or a sister to Stemonaceae in the Stemonales (Stevenson & Loconte 1995). The discrepancy between these two analyses concerning the phylogenetic position of Trilliaceae may have been affected by exclusion or inclusion of *Scoliopus* in the family. Several molecular analyses (Chase *et al.* 1995; Davis 1995; Kato *et al.* 1995b) suggested an unexpected relationship of the Trilliaceae with certain members of the Melanthiaceae (i.e. *Veratrum* and *Amianthium*).

Paris sensu lato is a genus with 20 perennial species distributed from Europe to the Far East. Most species, however, are restricted to Asia, chiefly in China, except for a European species (*Paris quadrifolia* L.) and a Caucasian species (*Paris incompleta* M. Bieb.). The generic limits of *Paris* have not been satisfactorily defined despite several treatments (Tatewaki & Suto 1935; Hara 1969; Takhtajan 1983; Li 1984, 1986; Mitchell 1987, 1988; Li 1988; Li & Noltie 1997). Hara (1969) divided the genus into three sections: sect. *Paris*, sect. *Kinugasa* and sect. *Euthyra*. In contrast, Takhtajan (1983) concluded that *Paris* is a collective genus which consists of three distinct genera: *Paris sensu stricto* (four species), *Kinugasa* (one species), and *Daiswa* (15 species). Li (1984) like Hara's (1969) treatment, maintained *Paris sensu lato* but divided it into two subgenera, viz., *Paris* and *Daiswa* with three sections (*Paris*, *Kinugasa* and *Axiparis*) and four sections (*Daiswa*, *Dunniana*, *Marmorata* and *Fargesiana*). We have followed Takhtajan's treatment (1983) in recognizing the three different genera.

Within the family, *Trillium* is the largest genus comprising approximately 48 species distributed disjunctly between North America and eastern Asia. Phylogenetic affinities and evolutionary divergence within this genus have been elucidated in our more recent molecular analyses (Kato *et al.* 1995a; Kazempour Osaloo *et al.* 1999).

Trillium and *Paris* plus segregates (*Daiswa* and *Kinugasa*) are separated morphologically by the nature of the floral and leaf whorls: trimerous flower and three leaves per whorl in *Trillium* versus tetra- to decamerous flower and four to 22 leaves per whorl in the latter taxa.

Although a recent phylogenetic study of Trilliaceae *sensu lato* using sequences of chloroplast gene *rbcL* (Kato *et al.* 1995b) supported the monophyly of the Trilliaceae, it did not clearly resolve relationships of the four genera (represented by *Paris tetraphylla*, *Kinugasa japonica*, *Daiswa polyphylla*, *Trillium camschatcense* and *Trillium sessile*), because there were few base substitutions among these taxa's *rbcL* genes.

Therefore, in the present study, the two chloroplast genes, *matK* and *rbcL*, and internal transcribed spacers

(ITS) of 18S–26S nuclear ribosomal DNA (nrDNA) were sequenced for further phylogenetic reconstructions. *rbcL* is a gene encoding the large subunit of ribulose-1, 5-bisphosphate carboxylase and is appropriate for phylogenetic analysis at the familial or generic level (Soltis *et al.* 1990; Shinwari *et al.* 1994; Kato *et al.* 1995b; Tanaka *et al.* 1997) and sometimes at the specific level (Yasui & Ohnishi 1998). The *matK* gene, encodes for maturase and has evolved approximately three times faster than *rbcL* (Johnson & Soltis 1994, 1995; Liang & Hilu 1996). It appears appropriate for analysis mostly at both the specific (Soltis *et al.* 1996; Kazempour Osaloo *et al.*, 1999) and generic levels (Johnson & Soltis 1994; Liang & Hilu 1996).

The nrDNA has also proven to be a useful phylogenetic tool, because it is ubiquitous in all organisms and is represented as repeating units in high copy numbers. The nrDNA units, separated in numerous replications by intergenic spacers, consists of the the 18S, 5.8S and 26S coding regions in plants (Knaak *et al.* 1990; Hamby & Zimmer 1992). Internal transcribed spacer sequences of 18S–26S nrDNA have been shown to provide a good phylogenetic resolution at the lower taxonomic level (e.g. closely related genera), because the sequences of spacer regions evolve more rapidly than coding regions (Baldwin 1992; Baldwin *et al.* 1995).

The primary purposes of this paper therefore are: (i) to reconstruct *rbcL*, *matK* and ITS phylogenies separately for the genera *Trillium*, *Paris*, *Daiswa*, *Kinugasa*; (ii) to compare the *rbcL* and in particular *matK* phylogenies with the ITS phylogeny of the genera, and to test monophyly of the genus *Trillium* in light of these molecular data; and (iii) to reconstruct a phylogenetic tree resulting from amino acid sequences of maturase and compare the phylogenetic position of *T. rivale* in both amino acid and *matK* trees; and (iv) finally to assess molecular evolution and phylogenetic utility of chloroplast genes, *rbcL* and *matK*, and ITS region of nrDNA.

Materials and methods

Plant samples

Twenty-six taxa of Trilliaceae were included in both *matK* and ITS sequence analyses, and 20 taxa were sequenced for *rbcL* (Table 1). *Veratrum maackii* (Melanthiaceae) was used as the outgroup for the cladistic analysis of the family (Chase *et al.* 1995; Davis 1995; Kato *et al.* 1995b; Kawano *et al.* unpubl. data on the Liliiflorae *sensu*; Dahlgren *et al.* 1985; Kazempour Osaloo *et al.* 1999)

Voucher specimens of the plants analyzed are deposited in the Herbaria of Kyoto University (KYO) and the Carnegie Museum of Natural History (CM). The DNA sequence data used in this study were registered in the DNA Data Bank of Japan (DDBJ) (Table 1).

Table 1 Taxa included in the *matK*, *rbcl* and internal transcribed spacer (ITS) sequencing analyses

Taxa	Locality	Collector(s)	DDBJ accession numbers*
1. <i>Trillium camschatcense</i> Ker-Gawler	Japan: Hokkaido, Samani-cho	H. Kato	AB017379, D28165, AB018808
2. <i>T. govonianum</i> Wallich ex Royle	Bhutan: Himalayas, Shin-gonpa	S. Umezawa	AB017391, AB018839, AB018813
3. <i>T. erectum</i> L.	USA: Pennsylvania; Westmoreland Co.	S. Kawano <i>et al.</i>	AB017388, AB018838, AB018812
4. <i>T. rugelii</i> Rendle	Japan: Cult. in Bot. Gard. of Hokkaido Univ.	Unknown	AB017405, AB018846, AB018823
5. <i>T. grandiflorum</i> (Michaux) Salisb.	USA: Pennsylvania; Westmoreland Co.	S. Kawano <i>et al.</i>	AB017392, D28164, AB018814
6. <i>T. ovatum</i> Pursh	USA: California; Del Norte Co.	S. Kawano <i>et al.</i>	AB017399, AB018840, AB018817
7. <i>T. pusillum</i> Michaux	USA: North Carolina, Sokes Co.	S. Kawano <i>et al.</i>	AB017401, AB018842, AB018819
8. <i>T. undulatum</i> Willdenow	USA: Pennsylvania; Westmoreland Co.	S. Kawano <i>et al.</i>	AB017413, AB018848, AB018825
9a. <i>T. rivale</i> S. Watson [†]	USA: California; Del Norte Co.	S. Kawano <i>et al.</i>	AB017404, D28166, AB018822
9b. <i>T. rivale</i> S. Watson [†]	USA: Oregon; Takilma, Siskiyou Nat. For.	K. Hayashi <i>et al.</i>	AB017404, AB018845, AB018822
9c. <i>T. rivale</i> S. Watson	USA: Oregon; Josephine Co. Eight Dollar Rd.	S. Kawano <i>et al.</i>	AB017404
10. <i>T. recurvatum</i> Beck	USA: Arkansas; Newton Co.	M. Ohara <i>et al.</i>	AB017402, AB018843, AB018820
11. <i>T. lancifolium</i> Rafin. [‡]	USA: South Carolina; McCormick Co.	M. Ohara <i>et al.</i>	AB017394, AB018815
12. <i>T. sessile</i> L.	USA: Pennsylvania; Westmoreland Co.	S. Kawano <i>et al.</i>	AB017406, AB018847, AB018824
13. <i>T. chloropetalum</i> (Torrey) Howell	USA: California; Santa Cruz Co.	M. Ohara <i>et al.</i>	AB017382, AB018837, AB018809
14. <i>T. maculatum</i> Rafin. [‡]	USA: Georgia; Early Co., Dry Creek	M. Ohara <i>et al.</i>	AB017397, AB018816
15. <i>T. decipiens</i> Freeman [†]	USA: Florida; Jackson Co.	M. Ohara <i>et al.</i>	AB017385, AB018810
16. <i>T. reliquum</i> Freeman	USA: Georgia; Columbia Co.	M. Ohara <i>et al.</i>	AB017403, AB018844, AB018821
17. <i>T. discolor</i> Wray ex Hooker [†]	USA: South Carolina; McCormick Co.	M. Ohara <i>et al.</i>	AB017387, AB018811
18. <i>T. petiolatum</i> Pursh	USA: Washington; Chelan Co.	M. Ohara <i>et al.</i>	AB017400, AB018841, AB018818
19. <i>Daiswa fargesii</i> (Franchet) Takht.	Japan: Cult. in Bot. Gard. of Setsunan Univ.	J. Murata & H. Murata	AB018827, AB018835, AB018800
20. <i>D. polyphylla</i> (Smith) Rafin.	Thailand: Chiang Mai; Doi Inthanon	M. N. Tamura	AB018828, D28155, AB018801
21. <i>D. thibetica</i> (Franchet) Takht. [‡]	UK: Cult. in Royal Bot. Gard. of Edinburgh.	Unknown	AB018829, AB018802
22. <i>D. violacea</i> (Leveille) Takht.	Japan: Cult. in Bot. Gard. of Setsunan Univ.	J. Murata & H. Murata	AB018830, AB018836, AB018803
23. <i>Kinugasa japonica</i> (Franchet et Savat.) Tatew. et. sato	Japan: Toyama; Tateyama-machi, Mt. Tateyama	H. Kato	AB018831, D28157, AB018804
24. <i>Paris incompleta</i> M. Bieb. [‡]	UK: Cult. in Royal Bot. Gard. of Edinburgh.	Unknown	AB018832, AB018805
25. <i>P. tetraphylla</i> A. Gray	Japan: Hokkaido; Hakodate city, Mt. Hakodate-yama	H. Kato	AB018833, D28159, AB018806
26. <i>P. verticillata</i> M. Bieb.	Japan: Hokkaido; Hakodate city, Mt. Hakodate-yama	H. Kato	AB018834, D28160, AB018807
27. <i>Veratrum maackii</i> Regel	Japan: Gifu, Nyukawa-mura	H. Kato	AB017417, AB018849, AB018826

*DDBJ accession numbers in each line were arranged for *matK*, *rbcl* and ITS, respectively.[†]Pairwise sequence divergence of *rbcl* for those samples differs only in one nucleotide site, so that only the sequence with DDBJ accession number of AB018845 were included in the phylogenetic analysis.[‡]The *rbcl* was not sequenced for that taxon.

DNA extraction

Total genomic DNA was extracted from fresh or silica gel-dried leaves using the modified CTAB method of Doyle and Doyle (1987).

Polymerase chain reaction

Polymerase chain reaction (PCR) amplification of nearly the entire *rbcl* gene (1411 b.p.) was performed using two

primers: *rbcl*N' and DBRBAS2 (Terachi *et al.* 1987). To obtain the sequence of the 5' end of the *rbcl* gene, the amplification was performed using an additional primer, *atp*β-232, corresponding to the *atp*β gene, upstream from the *rbcl* gene. The *matK* gene was amplified using primers *trnK*-FF74 (Yoshida & Hayashi, unpubl. data) and *trnK*-2R (Steele & Vilgalys 1994). Double-stranded DNA of the complete ITS region was amplified using primers ITS-4 and ITS-5 of White *et al.* (1990).

For the PCR amplification, each reaction mixture (100 µL) contained 54 µL of sterile water, 10 µL of 10×Taq polymerase reaction buffer (Toyobo, Osaka, Japan), 10 µL of 25 mmol/L MgCl₂, 16 µL of 1.25 mmol/L dNTPs (Toyobo, Japan), 4 µL of each of the two primers (40 pmol), 0.4 µL (2 units) of Taq polymerase (Toyobo), and 2 µL of genomic DNA template (20–50 ng). Amplification was done in a DNA Thermal Cycler (Perkin Elmer Cetus, Norwalk, CT, USA) for 35 cycles. Each PCR cycle proceeded in the following manner: (i) 1 min at 94°C to denature the double-stranded template DNA; (ii) 2 min at 50°C to anneal primers to single-stranded DNA; and (iii) 3 min at 72°C to extend primers. The first cycle was preceded by an initial denaturation step of 2 min at 94°C, and a final extension at 72°C for 7 min followed completion of the 35 cycles. Each set of reactions was monitored by the inclusion of a negative (no template) control. To remove unused amplifying primers and dNTPs, the PCR product was electrophoresed in a 1% agarose gel (using 1 × TAE as the gel buffer) stained with ethidium bromide, and then excised under low wavelength UV light with a scalpel. The gel slice containing the DNA fragment was transferred to a 1.5 mL microcentrifuge tube and the DNA was recovered from the agarose gel using the Gene Clean II Kit (Bio 101, Inc., Vista, CA, USA) according to the manufacturer's instruction. The purified DNA was resuspended in 20 µL of sterile water.

DNA sequencing

Purified double-stranded DNAs were then used in cycle sequencing reactions that were conducted using the Prism™ Dye Deoxy Terminator Cycle Sequencing Ready Reaction Kit (Applied Biosystems (ABI), Warrington, UK). The cycle sequencing reaction mixture contained 80 ng of template DNA, 8 µL of terminator premix, 3.2 µL of primers (3.2 pmol), and the appropriate amount of sterile water for a total volume of 20 µL. The cycle sequencing involved 25 cycles of denaturation for 30 s at 96°C, annealing for 15 s at 50°C, and extension for 4 min at 60°C; reactions were then held at 4°C. Following the cycle sequencing, the reactions were purified using the Ethanol Precipitation Protocol 1 (according to the Perkin Elmer Corporation's instruction protocol, revision A, August 1995) to remove unincorporated dye terminators and then completely dried in a vacuum. The reaction pellets were resuspended in 6 µL of loading buffer (five parts of deionized formamide to one part of a mixture of 25 mmol/L EDTA and blue dextran) and analyzed in an ABI Prism™ 377 DNA Sequencer using 50% Long Ranger (a gel solution) run in 1 × TBE buffer.

Primers for amplifying and sequencing the *rbcL*, and *matK* genes and ITS region are given in Table 2.

Data analysis

The *rbcL* sequences were easily aligned with SeqEd program (version 1.0.3, Applied Biosystems, Inc.) and no insertion/deletion events (indels) were detected.

The *matK* sequences were also easily aligned with SeqEd program, the few indels did not hinder the alignment. Since these indels were already included in the phylogenetic analysis of *Trillium* (Kazempour Osaloo *et al.* 1999), for the present study, we removed them from the data matrix. Our ITS sequences were aligned by hand and SeqEd program. Indels of the ITS region were also scored as missing characters to prevent overweighting and the phylogenetic distribution of each indel considered a posteriori by mapping its occurrence on the consensus tree based on nucleotide substitutions. By using SeqEd program, the *matK* sequences were directly translated to amino acid sequences of maturase and they were easily aligned. Indels of amino acid sequences were scored as binary (presence/absence) characters and together with the sequences were included in the phylogenetic analysis. We employed two different methods for phylogeny reconstruction: maximum parsimony (Fitch 1971, 1977) and neighbor-joining (Saitou & Nei 1987).

Phylogenetic analyses using the maximum parsimony method were performed with PAUP version 3.1.1 (Swofford 1993) for each of the data set. The most parsimonious trees were obtained using the heuristic search option involving 100 replications of random addition sequence and tree-bisection-reconnection (TBR) branch-swapping. All characters were specified as unweighted. To obtain confidence limits for various clades, a bootstrap analysis (Felsenstein 1985) was conducted. Bootstrap values with 1000 replications were calculated using the heuristic search option (with TBR branch-swapping and simple addition sequence algorithms).

For the neighbor-joining method, the computer program PHYLIP, version 3.57c (Felsenstein 1995), was separately used for each data set. To obtain the neighbor-joining tree, the following procedures were conducted: Kimura's (1981) two-parameter estimates of the evolutionary distance were calculated using the DNADIST program of PHYLIP. The resulting distance matrix was then analyzed by the NEIGHBOR program of PHYLIP to obtain the tree. The SEQBOOT program of PHYLIP (1000 replicates) was used to assign a bootstrap confidence value to each branch of the tree.

Results

rbcL sequence data

Partial sequences of *rbcL* gene (1390 b.p.) was determined for 20 taxa of Trilliaceae and for one outgroup species

Table 2 Location and base composition of amplification and sequencing primers used in this study

Primer	5' sequence 3'	Location ^{a,b}	Designed by
<i>rbcL</i>			
<i>rbcLN</i>	ATGTCACCACAAACAGAAACT	1–21	Terauchi <i>et al.</i> 1987
S2	AAAACCTTCCAAGGCC	435–451	Terauchi <i>et al.</i> , unpubl.
S4	AATGCATGCAGTTATTG	887–903	Terauchi <i>et al.</i> , unpubl.
DBRBAS2	GCTTGAATTCCAATTGATC	1411–1392	Terauchi <i>et al.</i> 1987; Terauchi, unpubl.
TRRV1	TAGAGACCCAATCTTGAGTG	1111–1092	Terauchi <i>et al.</i> , unpubl.
RV5	CCGTAGTTCTTTGCGGATAA	557–538	Terauchi <i>et al.</i> , unpubl.
RV4	TCAGTCCACACAGTTGTCCA	215–196	Terauchi <i>et al.</i> , unpubl.
<i>atpB232</i>	CCGTCCGTAGCATCATAGC	<i>atpB232</i>	Howe <i>et al.</i> 1985; Moon <i>et al.</i> 1987
<i>matK</i>			
<i>trnK</i> -FF74	ATACCCTGTTCCGACCATTG	676–697	Yoshida & Hayashi, unpubl.
<i>matK</i> -AF	CTATATCCACTTATCTTTCAGGAGT	804–828	Ooi <i>et al.</i> 1995
<i>matK</i> -BF	TCAGAAGGTTTTGCAGTCATTGTGG	1059–1083	Ooi <i>et al.</i> 1995
<i>matK</i> -TF1	TAGTTCAAATCCTTCAATGCTGG	1252–1274	Kazempour Osaloo & Murakami*
<i>matK</i> -TF2	TGTAATAATAAATCCTTCGGCGG	1793–1815	Kazempour Osaloo & Murakami*
<i>matK</i> -CF	TTGACCGATTTGGGCGTATATGCAG	1966–1990	Yoshida & Hayashi, unpubl.
<i>trnK</i> -2R	AACTAGTCGGATGGAGTAG	2573–2555	Steele & Vilgalys 1994
<i>matK</i> -8R	AAAGTTCTAGCACAAGAAAGTCGA	2104–2071	Ooi <i>et al.</i> 1995
<i>matK</i> -TR1	CCGCCGAAGGATTATTAGTACA	1815–1793	Kazempour Osaloo & Murakami*
<i>matK</i> -TR2	CCAGCATTGAAGGATTTGAACTA	1274–1252	Kazempour Osaloo & Murakami*
<i>matK</i> -AR	CTGTTGATACATTCGA	956–941	Yoshida & Hayashi, unpubl.
ITS			
ITS5	GGAAGTAAAAGTCGTAACAAGG	18S nrDNA	White <i>et al.</i> 1990
ITS3	GCATCGATGAAGAACGTAGC	5.8S nrDNA	White <i>et al.</i> 1990
ITS4	TCCTCCGCTTATTGATATGC	26S nrDNA	White <i>et al.</i> 1990
ITS2	GCTACGTTCTTCATCGATGC	5.8S nrDNA	White <i>et al.</i> 1990

* Designed in this study. ^a Location indicates the start and end nucleotide positions relative to *rbcL* sequences of wheat, *Dioscorea bulbifera*, several species of Liliiflorae, and rice. ^b Location indicates the start and end nucleotide positions relative to *matK* sequences of tobacco (Sugita *et al.* 1985).

Table 3 Comparison of sequence divergence and phylogenetic information from variable sites among two chloroplast genes, *rbcL* and *matK*, and the internal transcribed spacer (ITS) region of nuclear ribosomal DNA

DNA region	Average of percentage sequence divergence ^a	No. variable sites	No. informative sites ^b	Percentage informative sites ^c	No. homoplasious sites ^d	No. synapomorphic sites ^e	Percentage synapomorphic sites ^f
<i>rbcL</i>	0.55	35	16	45.71	9	7	43.75
<i>matK</i>	0.98	84	46	54.76	13	33	71.74
ITS	6.16	199	113	56.78	67	46	40.71

^a Average of percentage pairwise sequence divergences estimated using Kimura's (1981) two-parameter method. The same taxa (26 species) of Trilliaceae were sequenced for both *matK* and ITS, but 20 taxa of the family were included for sequencing of *rbcL*. ^b At a phylogenetically informative site, a nucleotide substitution is shared by two or more species. ^c Percentage of phylogenetically informative sites among the total number of variable sites. ^d Homoplasious sites of a DNA region are those where nucleotide substitutions phylogenetically conflict with the other substitutions in this region. ^e Difference between number of informative sites and number of homoplasious sites. ^f Percentage of synapomorphic sites among informative sites.

(*Veratrum maackii*). A total of 35 variable nucleotide positions was found among the ingroup taxa; 16 of these are potentially informative. Of these 16 informative sites, nine are homoplasious (Table 3). Phylogenetic analysis of the *rbcL* sequences resulted in 19 equally most parsimo-

nious trees each with a length of 108 steps, a consistency index (CI) of 0.852 (0.610 excluding autapomorphies), a homoplasy index (HI) of 0.148, and a retention index (RI) of 0.771. A strict consensus tree with its bootstrap values is shown in Fig. 1.

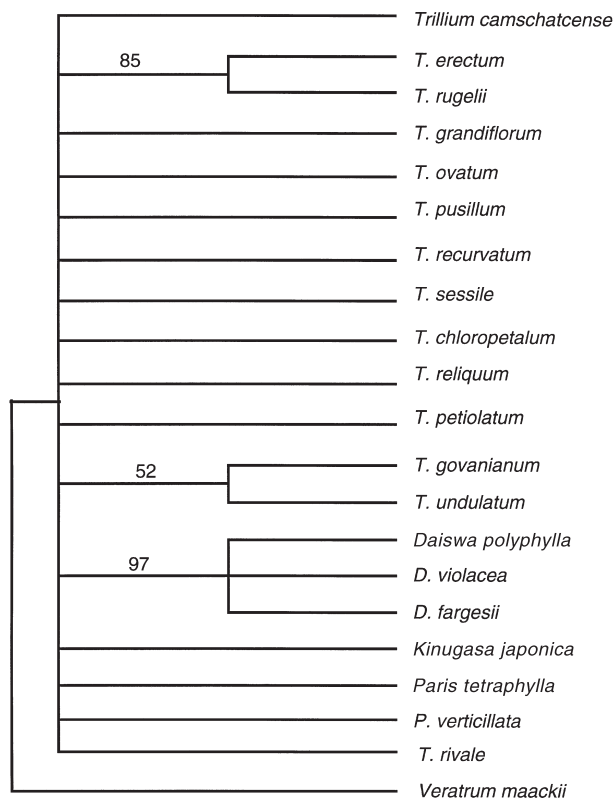

Fig. 1 Strict consensus of the 19 most parsimonious trees resulting from phylogenetic analysis of *rbcL* sequences for 20 taxa of Trilliaceae and *Veratrum maackii*. Percentages above branches are bootstrap values.

There are three clades, namely, *T. erectum*–*T. rugelii* clade (with a bootstrap value of 85%), *T. govanianum*–*T. undulatum* clade (52%), and *Daiswa* clade with three species (97%) in this tree. However, the phylogenetic relationships among these clades and the remaining taxa of the family are not resolved, because there are few informative nucleotide sites among *rbcL* genes of the taxa examined (see Table 3).

matK sequence data

The sequence alignment of the *matK* gene provided a matrix of 1608 b.p. Among taxa of the Trilliaceae, the length of the *matK* gene varies from 1542 b.p. (*T. petiolatum*) to 1566 b.p. (*T. erectum* and *T. rugelii*). Several indels of six or 15 nucleotides were detected among ingroup taxa and the outgroup species. These indels were previously detected among *Trillium* species and *Veratrum maackii* as a reference taxon (Table 4 in Kazempour Osaloo *et al.* 1999). A total of 84 variable nucleotide sites occur among the ingroup taxa; 46 of these are phylogenetically informative. Of these 46 informative sites, 13 are homoplasious (Tables 3 and 8). Pairwise sequence divergence values are

presented in Table 4. They range from 0.00 (e.g. between *T. recurvatum* and *T. lancifolium*) to 1.77% (e.g. between *T. govanianum* and *T. rivale*) among the ingroup taxa.

Phylogenetic analyses of the sequence data generated 33 equally most parsimonious trees each with a length of 281 steps, CI of 0.911 (0.702 excluding autapomorphies), HI of 0.089, and RI of 0.848. The 50% majority-rule consensus tree of these trees (Fig. 2) reveals that the family Trilliaceae is composed of one major clade and a single most basally diverged species, *Trillium rivale*. The major clade is, in turn, composed of two large subclades, and two species, *T. govanianum* and *T. undulatum*.

One subclade comprises the genera *Paris*, *Kinugasa* and *Daiswa*. The species of *Paris* form a weakly supported group (44% bootstrap value) which is a sister to a clade comprising *Kinugasa japonica* and *Daiswa* species. Together, these taxa form a monophyletic group (58% bootstrap value). This clade, *T. govanianum* and *T. undulatum* form a monophyletic group with another large subclade which comprises *Erectum* (*T. erectum*, *T. rugelii* and *T. camschatcense*), *Pusillum* (*T. pusillum*), *Grandiflorum* (*T. grandiflorum* and *T. ovatum*) groups and subgenus *Phyllantherum* (= *Sessile* group including *T. recurvatum*, *T. lancifolium*, *T. sessile*, *T. chloropetalum*, *T. maculatum*, *T. decipiens*, *T. reliquum*, *T. discolor* and *T. petiolatum*) of *Trillium*. The topology of the neighbor-joining tree based on the *matK* coding region (Table 4) almost coincides with that of the parsimony tree, and the clades that showed high bootstrap values in parsimony were usually supported in the neighbor-joining tree (figure not shown).

Internal transcribed spacer sequence data

The sequence boundaries of two ITS regions and three coding regions (18S, 5.8S and 26S) of nrDNA in the 27 taxa included here were determined by comparison to those of *Oryza sativa* (Takaiwa *et al.* 1985) and of *Daucus carota* and *Vicia faba* (Yokota *et al.* 1989). The size and G+C content of the ITS1, 5.8S, and ITS2 regions of the Trilliaceae and outgroup species are presented in Table 5. The total length of the ITS1, 5.8S, and ITS2 regions of the family ranges from 619 b.p. to 639 b.p. The length of ITS1 (241–245) is longer than that of ITS2 (213–230), and 5.8S is 164 b.p. long.

The percentage of G+C content ranges from 49.6% to 59.1% in ITS1, 50.0% to 52.4% in 5.8S, and 58.3% to 65.8% in ITS2. These molecular characteristics of ITS are similar to those of many other flowering plants examined (Baldwin 1992; Kim & Jansen 1994; Baldwin *et al.* 1995; Sang *et al.* 1995; Ro & McPherson 1997). Alignment of the entire ITS1, 5.8S, and ITS2 regions for the 26 ingroup taxa and for the one outgroup species resulted in a matrix of 711 characters. The alignment required approximately 54 gaps, ranging between 1 and 18 b.p., mostly 1–2 b.p. in size. Only 33 indels (Table 6), however, occurred among

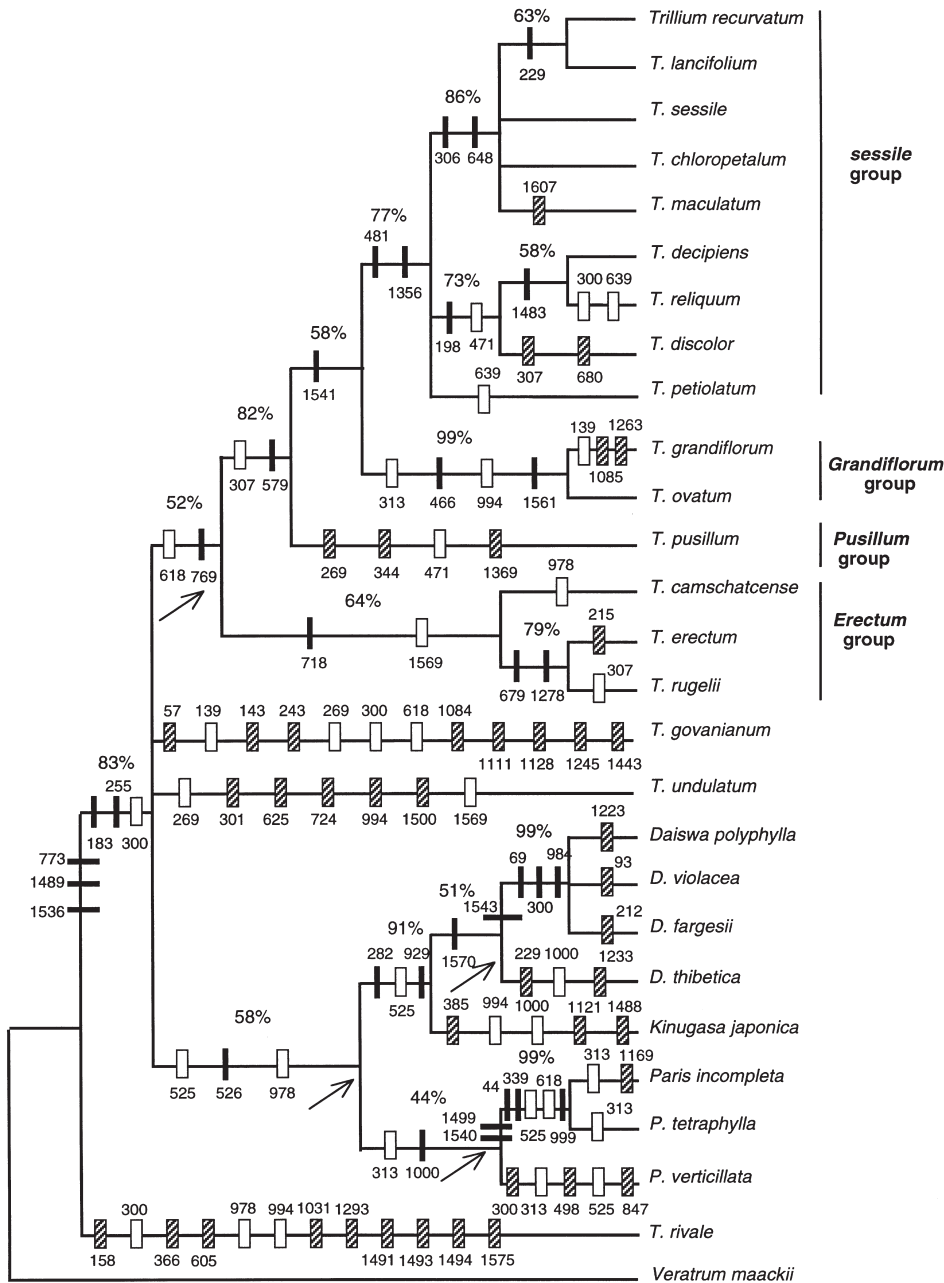

Fig. 2 Fifty per cent majority-rule consensus of 33 trees resulting from phylogenetic analysis of *matK* sequences for 26 taxa of Trilliaceae and *Veratrum maackii*. Percentages above branches are bootstrap values. Arrows indicate the nodes that collapse in the strict consensus tree. Bars represent informative site changes with (□) and without (■) homoplasy, and autapomorphic site changes (▨).

the ingroup taxa, of which only nine (26%) were potentially phylogenetically informative.

The indels provided additional support for some clades (Fig. 3). Fifteen of the indels were inferred to be insertions and 18 were inferred to be deletions. Pairwise sequence divergence ranges from 0.00 (e.g. between *T. erectum* and *T. rugelii*, *T. recurvatum* and *T. lancifolium*) to 13.70 (between *T. rivale* and *D. fargesii*) among the ingroup taxa (Table 7). A total of 199 variable nucleotide sites occurs among the ingroup taxa, 113 of these are phylogenetically

informative. Of these 113 informative sites, 67 are homoplasious sites (Table 3). The maximum parsimony analysis generated 16 equally most parsimonious trees, each with a length of 472, CI of 0.742 (0.569 excluding autapomorphies), HI of 0.258, and RI of 0.690. A 50% majority-rule consensus tree is shown in Fig. 3. In this ITS tree like the *matK* tree, *Trillium rivale* is a sister species to the remainder of the family.

Members of *Paris* are a sister group to a clade comprising *Kinugasa japonica* and some *Daiswa* species.

Table 5 Size and G+C content of ITS1, ITS2 and 5.8S regions of nuclear ribosomal DNA from 26 taxa of Trilliaceae and *Veratrum maackii*

Taxa	Length, b.p. (GC%)			
	ITS1	5.8S	ITS2	Total
<i>Trillium rivale</i>	244 (55.3)	164 (51.2)	217 (59.0)	625
<i>T. undulatum</i>	242 (59.1)	164 (51.8)	228 (65.8)	634
<i>T. govianianum</i>	242 (58.7)	164 (51.8)	228 (65.8)	634
<i>T. pusillum</i>	245 (56.7)	164 (52.4)	230 (63.5)	639
<i>T. ovatum</i>	244 (53.6)	164 (51.8)	228 (63.6)	636
<i>T. grandiflorum</i>	243 (57.6)	164 (51.8)	228 (64.0)	635
<i>T. erectum</i>	243 (56.4)	164 (51.8)	228 (62.7)	635
<i>T. rugelii</i>	243 (56.4)	164 (51.8)	228 (62.7)	635
<i>T. camschatcense</i>	245 (54.7)	164 (51.8)	229 (64.2)	638
<i>T. recurvatum</i>	244 (56.9)	164 (51.8)	228 (64.5)	636
<i>T. lancifolium</i>	244 (56.5)	164 (51.8)	228 (64.5)	636
<i>T. sessile</i>	244 (57.4)	164 (51.8)	228 (64.5)	636
<i>T. chloropetalum</i>	244 (57.4)	164 (51.8)	228 (64.5)	636
<i>T. maculatum</i>	244 (56.5)	164 (51.8)	228 (64.0)	636
<i>T. decipiens</i>	244 (56.5)	164 (52.4)	228 (64.9)	636
<i>T. reliquum</i>	244 (57.0)	164 (52.4)	228 (64.9)	636
<i>T. discolor</i>	244 (56.6)	164 (52.4)	228 (63.6)	636
<i>T. petiolatum</i>	244 (57.0)	164 (51.8)	228 (64.5)	636
<i>Daiswa polyphylla</i>	243 (50.2)	164 (50.0)	228 (60.1)	635
<i>D. fargesii</i>	243 (49.7)	164 (50.6)	227 (59.4)	634
<i>D. violacea</i>	242 (50.8)	164 (51.2)	213 (59.2)	619
<i>D. thibetica</i>	243 (51.4)	164 (50.6)	228 (58.3)	635
<i>Kinugasa japonica</i>	241 (50.2)	164 (50.6)	228 (59.2)	633
<i>Paris tetrphylla</i>	243 (51.8)	164 (51.8)	230 (61.3)	637
<i>P. incompleta</i>	242 (49.6)	164 (51.8)	230 (59.1)	636
<i>P. verticillata</i>	242 (53.7)	164 (51.8)	228 (62.7)	634
<i>Veratrum maackii</i>	240 (47.0)	164 (51.8)	247 (51.8)	651

Together, these taxa form a monophyletic group. This clade (Fig. 3) is relatively weakly supported with a bootstrap value of 55%. Representative species of *Daiswa* together form a very well supported clade with a bootstrap value of 100%. *Trillium undulatum* and *T. govianianum* form a clade with a bootstrap value of 70%. Members of the *Trillium* subgenus *Phyllantherum* (*Sessile* group) form a strongly supported monophyletic group with a bootstrap value of 99%. *Trillium ovatum*, *T. pusillum* and *T. grandiflorum* form a weakly supported clade (25% of bootstrap) that is a sister group to the subgenus *Phyllantherum*. Three representatives of the *Erectum* group of the subgenus *Trillium* also form a strongly supported clade with bootstrap value of 99%.

The topology of the neighbor-joining tree (Fig. 4) resulting from the ITS region (Table 7) are different from that of the parsimony tree in some clades. For example, in the neighbor-joining tree, the *T. govianianum*–*T. undulatum* clade is a sister to the *Sessile* group (with a bootstrap value of 21%), whereas in the parsimony tree the *T.*

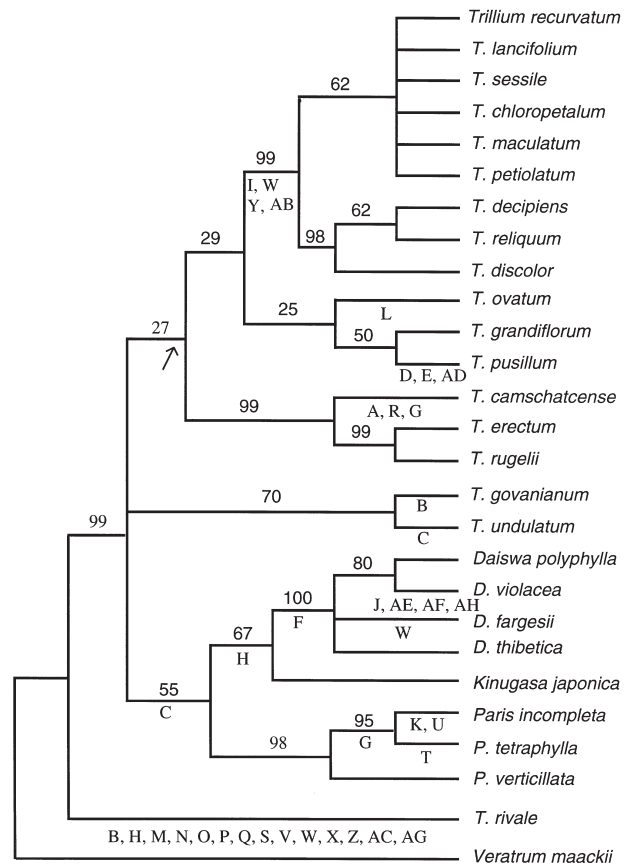

Fig. 3 Fifty per cent majority-rule consensus of the 16 most parsimonious trees resulting from phylogenetic analysis of internal transcribed spacer sequences for 26 taxa of Trilliaceae and *Veratrum maackii*. Percentages above branches are bootstrap values. Letters below the branches indicate the indels (Table 6) that change along that branch. Arrow indicates the node that collapses in the strict consensus tree.

grandiflorum–*T. pusillum*–*T. ovatum* clade is a sister to the *Sessile* group (with a bootstrap value of 29%).

Amino acid sequences of maturase

The sequence alignment of maturase provided a matrix of 535 amino acids. A total of 50 variable amino acid sites occur among the ingroup taxa; 29 of these are phylogenetically informative. Of these 29 informative sites, nine are homoplasious.

Phylogenetic analyses of the sequence data plus indels generated nine equally most parsimonious trees, each with a length of 183 steps, a CI of 0.902 (0.710 excluding autapomorphies), an HI of 0.098 and an RI of 0.849. A strict consensus tree of these trees (Fig. 5) reveals that *T. rivale*, together with clades *T. govianianum*–*T. undulatum*, *Daiswa*–*Kinugasa* and *Paris*, is basally diverged as a sister group to the remainder of *Trillium*.

Table 6 Insertion/deletion events among internal transcribed spacer (ITS) sequences of 26 taxa of Trilliaceae

Indel	Position(s)	No. base pairs	Type of event	Phylogenetically informative	Taxa
A	47	1	Insertion	No	<i>Trillium camschatcense</i>
B	50	1	Deletion	Yes	<i>T. govianum</i> , <i>T. rivale</i>
C	52	1	Deletion	Yes	<i>T. undulatum</i> , <i>Paris tetrphylla</i> , <i>P. incompleta</i> , <i>P. verticillata</i> , <i>Daiswa polyphylla</i> , <i>D. violacea</i> , <i>D. fargesii</i> , <i>D. thibetica</i> , <i>Kinugasa japonica</i>
D	84	1	Insertion	No	<i>T. pusillum</i>
E	91	1	Insertion	No	<i>T. pusillum</i>
F	94–5	2	Insertion	Yes	<i>D. polyphylla</i> , <i>D. violacea</i> , <i>D. fargesii</i> , <i>D. thibetica</i>
G	147	1	Insertion	Yes	<i>T. camschatcense</i> , <i>P. incompleta</i> , <i>P. tetrphylla</i>
H	152	1	Deletion	Yes	<i>T. rivale</i> , <i>D. polyphylla</i> , <i>D. violacea</i> , <i>D. fargesii</i> , <i>D. thibetica</i> , <i>K. japonica</i>
I	215	1	Insertion	Yes	<i>T. sessile</i> , <i>T. recurvatum</i> , <i>T. lancifolium</i> , <i>T. chloropetalum</i> , <i>T. maculatum</i> , <i>T. decipiens</i> , <i>T. reliquum</i> , <i>T. discolor</i> , <i>T. petiolatum</i>
J	218	1	Deletion	No	<i>D. violacea</i>
K	226	1	Deletion	No	<i>P. incompleta</i>
L	233	1	Insertion	No	<i>T. ovatum</i>
M	255–7	3	Insertion	No	<i>T. rivale</i>
N	480	1	Deletion	No	<i>T. rivale</i>
O	482–3	2	Deletion	No	<i>T. rivale</i>
P	486	1	Deletion	No	<i>T. rivale</i>
Q	489	1	Deletion	No	<i>T. rivale</i>
R	528	1	Insertion	No	<i>T. camschatcense</i>
S	537–8	2	Deletion	No	<i>T. rivale</i>
T	554–5	2	Insertion	No	<i>P. tetrphylla</i>
U	561–2	2	Insertion	No	<i>P. incompleta</i>
V	650–2	3	Deletion	No	<i>T. rivale</i>
W	653	1	Deletion	Yes	<i>T. rivale</i> , <i>T. sessile</i> , <i>T. recurvatum</i> , <i>T. lancifolium</i> , <i>T. chloropetalum</i> , <i>T. maculatum</i> , <i>T. decipiens</i> , <i>T. reliquum</i> , <i>T. discolor</i> , <i>T. petiolatum</i> , <i>D. fargesii</i>
X	655	1	Deletion	No	<i>T. rivale</i>
Y	656	1	Deletion	Yes	<i>T. sessile</i> , <i>T. recurvatum</i> , <i>T. lancifolium</i> , <i>T. chloropetalum</i> , <i>T. maculatum</i> , <i>T. decipiens</i> , <i>T. reliquum</i> , <i>T. discolor</i> , <i>T. petiolatum</i>
Z	657–8	2	Deletion	No	<i>T. rivale</i>
AB	662–3	2	Insertion	Yes	<i>T. sessile</i> , <i>T. recurvatum</i> , <i>T. lancifolium</i> , <i>T. chloropetalum</i> , <i>T. maculatum</i> , <i>T. decipiens</i> , <i>T. reliquum</i> , <i>T. discolor</i> , <i>T. petiolatum</i>
AC	667	1	Insertion	No	<i>T. rivale</i>
AD	686–7	2	Insertion	No	<i>T. pusillum</i>
AE	694	1	Deletion	No	<i>D. violacea</i>
AF	696–703	8	Deletion	No	<i>D. violacea</i>
AG	704–5	2	Insertion	No	<i>T. rivale</i>
AH	706–11	6	Deletion	No	<i>D. violacea</i>

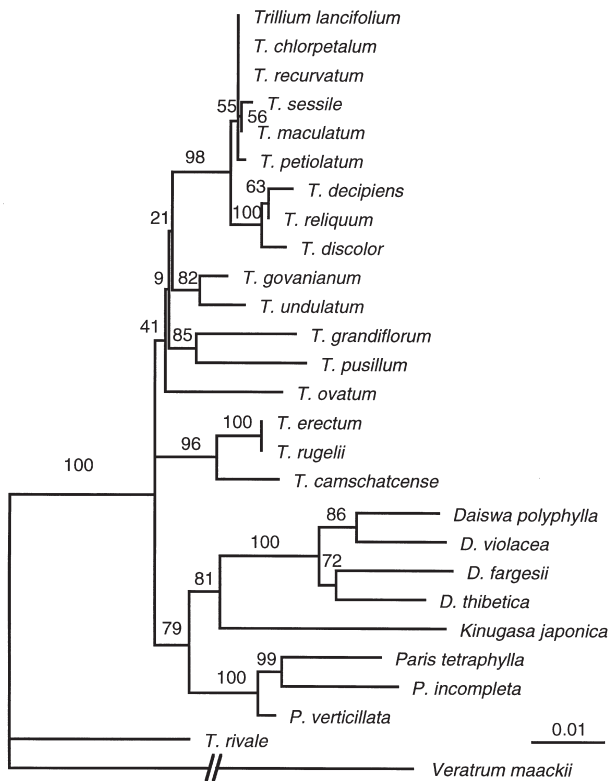

Fig. 4 Neighbor-joining distance tree resulting from phylogenetic analysis of internal transcribed spacer sequence data for 26 taxa of Trilliaceae and *Veratrum maackii*. Numbers above branches indicate bootstrap values. Scale indicates base substitution per site, 0.01.

Discussion

Evolutionary divergence within the genus *Trillium*

Phylogenetic analyses of *matK* and ITS sequence data set, not *rbcL* (Figs 2, 3), suggest that *Trillium* is paraphyletic, comprising one major clade, two loosely joined sister species (*T. govanianum* and *T. undulatum*) and a distantly related species, *T. rivale*. One of the unexpected findings of the present study is that *T. rivale* has its highest variability in both *matK* (Tables 4, 9) and ITS sequences (Table 7) relative to other members of the family. For this reason, this taxon diverges at the base of both the *matK* and ITS trees. In contrast, the phylogenetic analysis of amino acid sequences (Fig. 5) reveals that *T. rivale* together with clades *Paris*, *Daiswa*–*Kinugasa* and *T. govanianum*–*T. undulatum* is basally diverged as a sister group to the remaining *Trillium*. The phylogenetic position of *T. rivale* at the base of the *matK* tree is due to both homoplasious nucleotide sites with other ingroup taxa and especially shared sites [nucleotide positions of codon number: 61, 85, 258, 497, and 512 (Tables 8, 9)] with the outgroup species (*Veratrum maackii*); whereas in the amino acid trees, the position is affected by only homoplasious amino

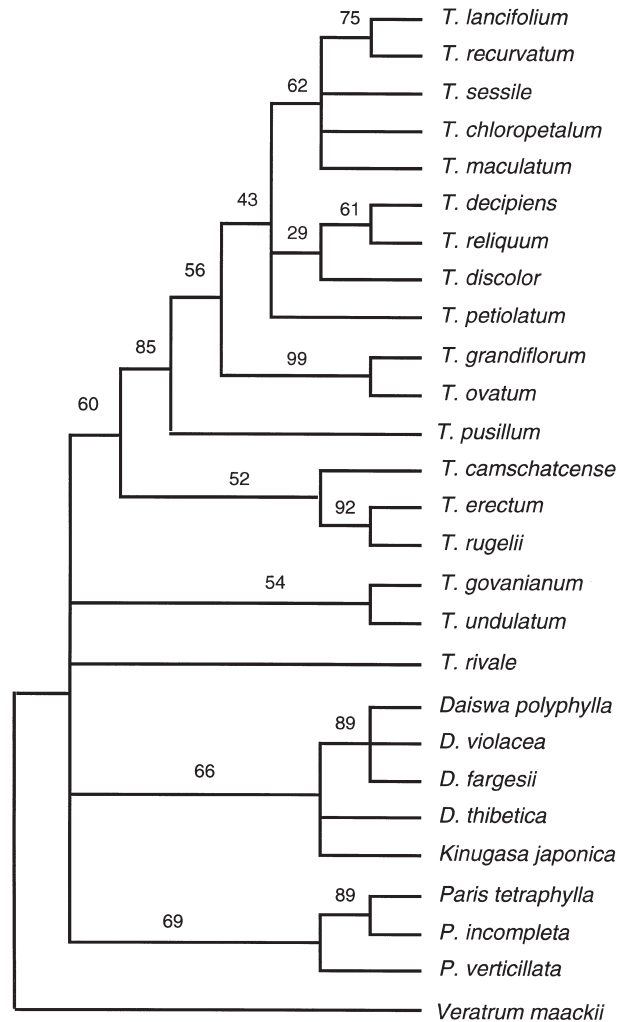

Fig. 5 Strict consensus of nine most parsimonious trees resulting from phylogenetic analysis of amino acid sequences (plus indels) of maturase (which encoded by *matK* gene) for 26 taxa of Trilliaceae and *Veratrum maackii*. Percentages above branches are bootstrap values.

acid sites with ingroup taxa (Table 8). This fact also suggests that there are at least several steps of missing links among the currently existing taxa and some unknown ancestral taxa of the Trilliaceae.

Both *rbcL* and ITS data rather than *matK* data reveal that *T. govanianum* and *T. undulatum* are sister taxa (Figs 1, 3, 4), but in the amino acid tree these two species again form a clade of a pair of species.

All phylogenetic analyses, excluding *rbcL*, provide strong support for the monophyly of the subgenus *Phyllantherum*. This finding is in agreement with earlier analyses, not only of *cpDNA* restriction fragment length polymorphisms (Kato *et al.* 1995a) but also of *matK* sequences (Kazempour Osaloo *et al.* 1999). Therefore, the very close similarities in terms of gross morphology (see

Table 7 Base pair differences (above diagonal) and number of base substitutions per site (below diagonal, given as $100 \times d$, calculated according to Kimura 1981) of internal transcribed spacer (ITS) sequences from 26 taxa of Trilliaceae

	<i>T. cam.</i>	<i>T. ere.</i>	<i>T. rug.</i>	<i>T. gra.</i>	<i>T. pus.</i>	<i>T. ova.</i>	<i>T. rec.</i>	<i>T. lan.</i>	<i>T. ses.</i>	<i>T. chl.</i>	<i>T. mac.</i>	<i>T. des.</i>	<i>T. rel.</i>	<i>T. dis.</i>	<i>T. pet.</i>	<i>T. gov.</i>	<i>T. und.</i>	<i>T. riv.</i>	<i>D. pol.</i>	<i>D. far.</i>	<i>D. vio.</i>	<i>D. thi.</i>	<i>D. K. jap.</i>	<i>P. tet. inc.</i>	<i>P. ver.</i>	
<i>Trillium camschatcense</i>	-	14	14	32	33	37	29	29	30	29	29	35	32	34	29	23	29	56	52	53	51	50	48	47	48	35
<i>T. erectum</i>	2.24	-	0	32	31	34	25	25	27	25	25	31	28	30	25	22	26	55	50	51	50	48	51	45	45	34
<i>T. rugeli</i>	2.24	0.00	-	32	31	34	25	25	27	25	25	31	28	30	25	22	26	55	50	51	50	48	51	45	45	34
<i>T. grandiflorum</i>	5.24	5.24	5.24	-	28	34	26	26	28	26	26	33	30	30	26	23	27	64	54	52	53	49	58	50	51	35
<i>T. pusillum</i>	5.39	5.05	5.05	4.55	-	34	28	28	30	28	28	35	32	34	28	27	29	62	56	51	53	52	59	50	51	37
<i>T. ovatum</i>	6.08	5.57	5.57	5.54	5.54	-	26	26	27	26	26	31	30	31	26	26	26	59	55	56	52	51	53	49	52	35
<i>T. recurvatum</i>	4.76	4.09	4.09	4.25	4.57	4.24	-	0	2	0	0	9	6	8	1	17	19	53	48	50	48	47	50	41	45	27
<i>T. lancifolium</i>	4.76	4.09	4.09	4.25	4.57	4.24	0.00	-	2	0	0	9	6	8	1	17	19	53	47	50	48	47	50	41	45	27
<i>T. sessile</i>	4.92	4.42	4.42	4.59	4.91	4.41	0.32	0.32	-	2	1	11	8	10	3	17	19	55	49	52	49	48	51	43	46	28
<i>T. chloropetalum</i>	4.75	4.08	4.08	4.24	4.56	4.23	0.00	0.00	0.32	-	0	9	6	8	1	17	19	54	48	51	48	47	50	42	45	27
<i>T. maculatum</i>	4.76	4.09	4.09	4.26	4.57	4.24	0.00	0.00	0.16	0.00	-	9	6	8	1	16	18	54	47	50	47	46	49	41	44	26
<i>T. decipiens</i>	5.77	5.09	5.09	5.42	5.74	5.07	1.43	1.43	1.75	1.43	1.43	-	3	7	10	24	26	60	54	54	55	57	55	45	48	32
<i>T. reliquum</i>	5.26	4.58	4.58	4.92	5.23	4.90	0.95	0.95	1.27	0.95	0.95	0.47	-	4	7	21	23	59	52	55	52	51	54	46	49	31
<i>T. discolor</i>	5.61	4.94	4.94	4.93	5.58	5.08	1.27	1.28	1.60	1.27	1.28	1.11	0.63	-	9	23	25	61	54	57	54	53	56	48	51	33
<i>T. petiolatum</i>	4.76	4.09	4.09	4.25	4.57	4.24	0.16	0.16	0.47	0.16	0.16	1.59	1.11	1.43	-	17	19	54	48	51	48	47	50	42	45	27
<i>T. govanianum</i>	3.73	3.58	3.58	3.74	4.39	4.22	2.75	2.76	2.75	2.75	2.59	3.91	3.41	3.76	2.76	-	10	50	44	46	43	42	45	38	41	25
<i>T. undulatum</i>	4.73	4.24	4.24	4.40	4.71	4.22	3.08	3.08	3.08	3.08	2.92	4.24	3.74	4.08	3.08	1.60	-	52	50	52	48	48	47	40	43	27
<i>T. rivale</i>	9.70	9.51	9.51	11.16	10.76	10.22	9.15	9.16	9.53	9.33	9.35	10.43	10.25	10.65	9.34	8.60	8.96	-	76	77	73	72	73	62	64	52
<i>Daiswa polyphylla</i>	8.73	8.36	8.36	9.07	9.38	9.22	8.04	7.86	8.22	8.03	7.88	9.08	8.73	9.11	8.04	7.32	8.34	13.47	-	32	22	30	58	59	61	46
<i>D. fargesii</i>	8.95	8.58	8.58	8.76	8.55	9.44	8.41	8.42	8.78	8.58	8.43	9.64	9.29	9.68	8.59	7.70	8.73	13.70	5.23	-	34	28	61	56	61	48
<i>D. violaceae</i>	8.82	8.62	8.62	9.17	9.13	8.96	8.29	8.29	8.47	8.28	8.12	9.55	9.00	9.40	8.29	7.36	8.24	13.27	3.65	5.72	-	31	54	59	58	46
<i>D. tibetica</i>	8.38	8.01	8.01	8.19	8.70	8.53	7.88	7.88	8.06	7.87	7.72	9.10	8.57	8.95	7.88	6.99	8.01	12.72	4.88	4.56	5.19	-	59	53	59	44
<i>Kimugasa japonica</i>	8.04	8.57	8.57	9.80	9.94	8.89	8.41	8.41	8.59	8.40	8.24	9.28	9.10	9.49	8.41	7.51	7.84	12.93	9.79	10.38	9.34	9.99	-	58	56	46
<i>Paris tetraphylla</i>	7.80	7.47	7.47	8.33	8.29	8.13	6.79	6.79	7.14	6.95	6.80	7.47	7.64	8.01	6.96	6.26	6.58	10.80	9.94	9.45	10.24	8.89	9.78	-	29	19
<i>P. incompleta</i>	7.98	7.47	7.47	8.51	8.47	8.65	7.48	7.48	7.66	7.47	7.32	7.99	8.17	8.55	7.48	6.77	7.10	11.18	10.30	10.35	10.05	9.96	9.43	4.70	-	22
<i>P. verticillata</i>	5.74	5.58	5.58	5.74	6.05	5.72	4.41	4.41	4.58	4.40	4.25	5.24	5.07	5.43	4.41	4.06	4.38	8.95	7.64	8.02	7.87	7.31	7.65	3.05	3.55	-

d, evolutionary genetic distance between the two taxa being studied.

Kawano & Kato 1995), *cpDNA* (Kato *et al.* 1995a; Kazempour Osaloo *et al.* 1999), and ITS sequence variations among the sessile-flowered species suggest a relatively recent evolutionary origin of this subgenus.

In the most parsimonious *matK* trees as well as in the trees resulting from the ITS data set, *T. camschatcense*, *T. erectum*, and *T. rugelii* form a distinct monophyletic group, the so-called *Erectum* group. This group appears in both trees as part of a large clade that also contains the *Grandiflorum* and *Sessile* groups. Furthermore, in all these molecular data sets, *T. erectum* and *T. rugelii* form a distinct clade, suggesting that this is one of the most natural groups within *Trillium* (see also Kato *et al.* 1995a; Kawano & Kato 1995; Kazempour Osaloo *et al.* 1999).

However, phylogenies of *Trillium* obtained from *matK* and ITS sequences are discordant in certain respects (see Figs 2, 3). For example, *T. grandiflorum* forms a strongly supported sister group with *T. ovatum* in the *matK* tree (99% bootstrap value), but switches its sister group relationship to *T. pusillum* in the ITS tree. This suggests that *T. grandiflorum* may be of hybrid origin that fixed ITS sequences of *T. pusillum* and inherited *cpDNA* from *T. ovatum*. Furthermore, the strongly supported relationship of the *Sessile* group and *T. grandiflorum*, *T. ovatum*, and *T. pusillum* in the *matK* tree (82% bootstrap value) receives much less support (29% bootstrap value) from the ITS data. This low supported relationship in the ITS tree is affected by a high number of homoplasious point mutations. Conversely, in the neighbor-joining tree (Fig. 4) resulting from the ITS data set, the *T. govianum*–*T. undulatum* clade is a sister to the *Sessile* group. Base pair differences between the *Sessile* group and the *T. govianum*–*T. undulatum* clade is unexpectedly lower than the differences between the *Sessile* group and the *T. grandiflorum*–*T. pusillum*–*T. ovatum* clade (see Table 7). In spite of the apparent relationship between *T. govianum*–*T. undulatum* clade and the *Sessile* group in the neighbor-joining tree, the bootstrap value is very low (21%), even lower than that of the parsimonious tree.

Another conflict between these two molecular phylogenies is found within the *Sessile* group. The *matK* tree reveals that *T. recurvatum* and *T. lancifolium* form a distinct clade, whereas such a clade is not recognized in the ITS tree. Furthermore, in the *matK* tree, *T. petiolatum* is a sister species to a clade which comprises *T. recurvatum*, *T. lancifolium*, *T. sessile*, *T. chloropetalum* and *T. maculatum* (see also Kazempour Osaloo *et al.* 1999), while in the ITS phylogeny, *T. petiolatum* is a member of this unresolved clade.

Phylogenetic relationships of Paris, Kinugasa and Daiswa and their affinities with Trillium

In both ITS and *matK* trees, except in the *rbcL* tree, *Paris*, *Kinugasa* and *Daiswa* form a relatively weakly supported

clade (with bootstrap values of 55% and 58%, respectively). Both the *matK* tree and in particular the ITS tree reveal that *P. tetraphylla*, *P. incompleta* and *P. verticillata* together form a distinct clade, with bootstrap values of 44% and 98%, respectively. These species as well as the tetraploid *P. quadrifolia* are characterized by a satellited D-type chromosome with a subterminal centromere in their basic complement and by a slender rhizome as well as by a bluish black, poisonous berry (Hara 1969; Takhtajan 1983; Li 1984). Therefore, molecular data (particularly the ITS data set) are in agreement with both karyological and morphological evidence and support the idea that the *Paris sensu stricto* (= *Paris* section *Paris sensu* Hara 1969; Li 1984) is a distinct monophyletic taxon. Within this clade, *P. tetraphylla* and *P. incompleta* are sister species (with high bootstrap support). The *matK* gene of both of these species is very similar and differ only in two base pairs (100d=0.13, where d is the evolutionary genetic distance between the two). *Paris tetraphylla* is endemic to Japan, while *P. incompleta* is limited to the Caucasus. Although these species are distributed in different geographic regions, they do share certain morphological characters, including the lack of petals and free portion of connective tissue beyond the anther.

Another unexpected finding of the present study is that both *matK* and ITS, rather than *rbcL*, suggest a very close relationship of *K. japonica* to species of *Daiswa*. *Kinugasa japonica* is a very distinct species endemic to Japan, growing in the subalpine forests along the Japan Sea side of Honshu. Morphologically, this species is characterized by very thick rhizomes, seven to 10 white petaloid sepals, a dark purple non-poisonous (edible) berry, and large pollen grains with gemmate exine sculpture (Tatewaki & Suto 1935; Hara 1969; Takhtajan 1983; Takahashi 1984). Cytogenetically, this taxon is unique in the Trilliaceae. It has 40 somatic chromosomes comprising four different genome sets (Haga 1934, 1937; Tatewaki & Suto 1935), and represents the most complicated C-banding pattern, and furthermore possesses the highest proportion of C-banding positive heterochromatin to euchromatin (Miyamoto *et al.* 1992). Therefore, this species is considered to be an allo-octaploid (Haga 1934, 1937; Tatewaki & Suto 1935; Miyamoto *et al.* 1992). The origin of this taxon has been debated for a long time and two major hypotheses have been proposed. One hypothesis based on chromosome morphology and banding pattern (Haga 1937; Fukuda 1990) considered *K. japonica* to be a natural intergeneric hybrid which might have originated in the Asian region from ancestors of the lower polyploid plants such as *T. tschonokii* and *P. polyphylla* (= *D. polyphylla*) types (cf. Miyamoto *et al.* 1992). Another hypothesis based mainly on evidence from gross morphology (Hara 1969) suggested that the species cannot be considered to be derived from any other recent

Table 8 Matrix of *matK* codons with phylogenetically informative nucleotide positions (boldface characters) from 26 taxa of Trilliaceae

Taxa	Codon number																		
	15	23	47	66	77*	90	94	100	102	103	105	113	156	157	161	175	176	193	206
<i>Trillium rivale</i>	TCT	CCG	TAC	GTG	AAT	CGA	CAC	TCA	TTT	TAT	CAA	GTC	CAT	TTA	TTA	GTT	CAA	TTC	TTT
<i>T. undulatum</i>	TCT	CCG	TAC	GTG	AAT	CTA	CAC	TCG	TTT	TAT	CAA	GTC	CAT	TTA	TTA	GTT	CAA	TTC	TTT
<i>T. govanianum</i>	TCT	CCG	GAC	GTG	AAT	CTA	CAC	TCA	TTT	TAT	CAA	GTC	CAT	TTA	TTA	GTT	CAA	TTC	TTG
<i>T. pusillum</i>	TCT	CCG	TAC	GTG	AAT	CAA	CAC	TCG	TTT	GAT	CAA	GTC	CAT	TTC	TTA	GTT	CAA	TTA	TTG
<i>T. ovatum</i>	TCT	CCG	TAC	GTG	AAT	CGA	CAC	TCG	TTT	GAT	AAA	GTC	TAT	TTA	TTA	GTT	CAA	TTA	TTG
<i>T. grandiflorum</i>	TCT	CCG	GAC	GTG	AAT	CGA	CAC	TCG	TTT	GAT	AAA	GTC	TAT	TTA	TTA	GTT	CAA	TTA	TTG
<i>T. rugelii</i>	TCT	CCG	TAC	GTG	AAT	CGA	CAC	TCG	TTT	GAT	CAA	GTC	CAT	TTA	TTA	GTT	CAA	TTC	TTG
<i>T. erectum</i>	TCT	CCG	TAC	GTG	AAT	CGA	CAC	TCG	TTT	TAT	CAA	GTC	CAT	TTA	TTA	GTT	CAA	TTC	TTG
<i>T. camtschatcense</i>	TCT	CCG	TAC	GTG	AAT	CGA	CAC	TCG	TTT	TAT	CAA	GTC	CAT	TTA	TTA	GTT	CAA	TTC	TTG
<i>T. lancifolium</i>	TCT	CCG	TAC	GTG	GAT	CGA	CAC	TCG	TTG	GAT	CAA	GTC	CAT	TTA	CTA	GTT	CAA	TTA	TTG
<i>T. recurvatum</i>	TCT	CCG	TAC	GTG	GAT	CGA	CAC	TCG	TTG	GAT	CAA	GTC	CAT	TTA	CTA	GTT	CAA	TTA	TTG
<i>T. sessile</i>	TCT	CCG	TAC	GTG	AAT	CGA	CAC	TCG	TTG	GAT	CAA	GTC	CAT	TTA	CTA	GTT	CAA	TTA	TTG
<i>T. chloropetalum</i>	TCT	CCG	TAC	GTG	AAT	CGA	CAC	TCG	TTG	GAT	CAA	GTC	CAT	TTA	CTA	GTT	CAA	TTA	TTG
<i>T. maculatum</i>	TCT	CCG	TAC	GTG	AAT	CGA	CAC	TCG	TTG	GAT	CAA	GTC	CAT	TTA	CTA	GTT	CAA	TTA	TTG
<i>T. decipiens</i>	TCT	CCG	TAC	GTA	AAT	CGA	CAC	TCG	TTT	GAT	CAA	GTC	CAT	TTC	CTA	GTT	CAA	TTA	TTG
<i>T. reliquum</i>	TCT	CCG	TAC	GTA	AAT	CGA	CAC	TCA	TTT	GAT	CAA	GTC	CAT	TTC	CTA	GTT	CAA	TTA	TTG
<i>T. discolor</i>	TCT	CCG	TAC	GTA	AAT	CGA	CAC	TCG	TTT	AAT	CAA	GTC	CAT	TTC	CTA	GTT	CAA	TTA	TTG
<i>T. petiolatum</i>	TCT	CCG	TAC	GTG	AAT	CGA	CAC	TCG	TTT	GAT	CAA	GTC	CAT	TTA	CTA	GTT	CAA	TTA	TTG
<i>Daiswa fargesii</i>	TCT	CCA	TAC	GTG	AAT	CGA	CAT	TCC	TTT	TAT	CAA	GTC	CAT	TTA	TTA	GTG	AAA	TTC	TTT
<i>D. polyphylla</i>	TCT	CCA	TAC	GTG	AAT	CGA	CAT	TCC	TTT	TAT	CAA	GTC	CAT	TTA	TTA	GTG	AAA	TTC	TTT
<i>D. thibetica</i>	TCT	CCG	TAC	GTG	CAT	CGA	CAT	TCG	TTT	TAT	CAA	GTC	CAT	TTA	TTA	GTG	AAA	TTC	TTT
<i>D. violacea</i>	TCT	CCA	TAC	GTG	AAT	CGA	CAT	TCC	TTT	TAT	CAA	GTC	CAT	TTA	TTA	GTG	AAA	TTC	TTT
<i>Kinugasa japonica</i>	TCT	CCG	TAC	GTG	AAT	CGA	CAT	TCG	TTT	TAT	CAA	GTC	CAT	TTA	TTA	GTG	AAA	TTC	TTT
<i>Paris incompleta</i>	TTT	CCG	TAC	GTG	AAT	CGA	CAC	TCG	TTT	TAT	CAA	GTG	CAT	TTA	TTA	GTT	AAA	TTC	TTG
<i>P. teraphylla</i>	TTT	CCG	TAC	GTG	AAT	CGA	CAC	TCG	TTT	TAT	AAA	GTG	CAT	TTA	TTA	GTT	AAA	TTC	TTG
<i>P. verticillata</i>	TCT	CCG	TAC	GTG	AAT	CGA	CAC	TCT	TTT	TAT	AAA	GTC	CAT	TTA	TTA	GTG	AAA	TTC	TTT
Codon with amino acid [†]	TCT	CCG	TAC	GTG	AAT	CGA	CAC	TCA	TTT	TAT	CAA	GTC	CAT	TTA	TTA	GTT	CAA	TTC	TTT
Ser	Pro	Tyr	Val	Asn	Arg	His	Ser	Phe	Tyr	Gln	Val	His	Leu	Leu	Val	Gln	Phe	Phe	
TTT	CCA	GAC	GTA	GAT	CTA	CAT	TCG	TTG	GAT	AAA	GTG	TAT	TTC	CTA	GTG	AAA	TTA	TTG	
Phe	Pro	Asp	Val	Asp	Leu	His	Ser	Leu	Asp	Lys	Val	Tyr	Phe	Leu	Val	Lys	Leu	Leu	
				CAT	CAA		TCC		AAT										
				His	Gln		Ser		Asn										
							TCT												
							Ser												

*Denotes codons with either informative or autapomorphic nucleotide positions.[†]Boldface amino acids are non-synonymous substitutions.

species of the family, and that it must be of very ancient origin, and may have common ancestors with the species of *Paris* (or section *Euthyra sensu* Hara=*Daiswa sensu* Takhtajan) or *Trillium*. Our molecular phylogenetic results (Figs 2, 3) are partly in agreement with the latter hypothesis (Hara 1969) and clearly suggest that the species is of relatively ancient origin and has a common ancestor with *Daiswa* rather than with any species of *Paris sensu stricto* or *Trillium*.

The ITS data unlike *matK* show that four *Daiswa* species studied here form a strongly supported clade. Most of the species of *Daiswa* which have thick rhizomes like that of *K. japonica*, are characterized by having a fleshy loculicidal dehiscent capsule (with the exception

of *D. forrestii* in which the fruit is an indehiscent berry [Li & Noltie 1997]) and seeds with a scarlet sarcotesta (Takhtajan 1983). Formerly, *D. violacea*, *D. fargesii* and *D. thibetica* were treated as infraspecific entities of the polymorphic *P. polyophylla* (= *D. polyophylla*) complex (Hara 1969). These species of *Daiswa* look very different from the others (Takhtajan 1983). *Daiswa thibetica* is remarkable in having elongated, slender free portion of connective tissue, 6–17.5 mm long (Takhtajan 1983, 1991). Cytogenetically, this species shows the simplest C-banding pattern and the lowest proportion of heterochromatin to euchromatin (Miyamoto *et al.* 1992). Although at the molecular level (*matK* sequence data, Table 4), this taxon is different from the three other *Daiswa*

213	216	227*	240	257	310	326	328	332	333	334	426	452	495	500*	514	515	521	523	524
AAA	TCC	CGG	GTA	GGA	GCT	GTA	TTC	CAT	TTT	CAC	ATT	ATA	ATT	CCA	AGA	GAA	GAC	ATC	CGT
AAA	TCC	CGG	GTA	GGA	GCT	GTC	TTC	TAT	TTT	CAC	ATT	ATA	ATT	CCC	AGA	GAA	GAC	ATT	CGT
AAA	TCC	CGG	GTA	GGA	GCT	GTC	TTC	AAT	TTT	CAC	ATT	ATA	ATT	CCA	AGA	GAA	GAC	ATC	CGT
AAA	TCC	CGG	GTA	CGA	GCT	GTC	TTC	AAT	TTT	CAC	ATT	ATA	ATT	CCA	AGA	GAA	GAC	ATC	CGT
AAA	TCC	CGG	GTA	CGA	GCT	GTC	TTC	CAT	TTT	CAC	ATT	ATA	ATT	CCA	AAA	GAA	AAC	ATC	CGT
AAA	TCC	CGG	GTA	CGA	GCT	GTC	TTC	CAT	TTT	CAC	ATT	ATA	ATT	CCA	AAA	GAA	AAC	ATC	CGT
AAA	TCC	TGG	TTA	CGA	GCT	GTC	TTC	AAT	TTT	CAC	ATG	ATA	ATT	CCA	AGA	GAA	GAC	ATT	CGT
AAA	TCC	TGG	TTA	CGA	GCT	GTC	TTC	AAT	TTT	CAC	ATG	ATA	ATT	CCA	AGA	GAA	GAC	ATT	CGT
AAA	TCC	CGG	TTA	CGA	GCT	GTA	TTC	AAT	TTT	CAC	ATT	ATA	ATT	CCA	AGA	GAA	GAC	ATT	CGT
AAA	TCT	CGG	GTA	CGA	GCT	GTC	TTC	AAT	TTT	CAC	ATT	ATC	ATT	CCA	AAA	GAA	GAC	ATC	CGT
AAA	TCT	CGG	GTA	CGA	GCT	GTC	TTC	AAT	TTT	CAC	ATT	ATC	ATT	CCA	AAA	GAA	GAC	ATC	CGT
AAA	TCT	CGG	GTA	CGA	GCT	GTC	TTC	AAT	TTT	CAC	ATT	ATC	ATT	CCA	AAA	GAA	GAC	ATC	CGT
AAA	TCT	CGG	GTA	CGA	GCT	GTC	TTC	AAT	TTT	CAC	ATT	ATC	CTT	CCA	AAA	GAA	GAC	ATC	CGT
AAA	TCT	CGG	GTA	CGA	GCT	GTA	TTC	AAT	TTT	CAC	ATT	ATC	CTT	CCA	AAA	GAA	GAC	ATC	CGT
AAA	TCC	CGG	GTA	CGA	GCT	GTC	TTC	AAT	TTT	CAC	ATT	ATC	ATT	CCA	AAA	GAA	GAC	ATC	CGT
AAT	TCC	CGG	GTA	CGA	GCT	GTC	TTC	AAT	TTT	CAC	ATT	ATC	ATT	CCA	AAA	GAA	GAC	ATC	CGT
AAA	TCC	CAG	GTA	CGA	GCT	GTC	TTC	AAT	TTT	CAC	ATT	ATC	ATT	CCA	AAA	GAA	GAC	ATC	CGT
AAT	TCC	CGG	GTA	CGA	GCT	GTC	TTC	AAT	TTT	CAC	ATT	ATC	ATT	CCA	AAA	GAA	GAC	ATC	CGT
AAA	TCC	CGG	GTA	GGA	GGT	GTA	TTA	AAT	TTT	CAC	ATT	ATA	ATT	CCA	AGA	AAA	GAC	ATC	TGT
AAA	TCC	CGG	GTA	GGA	GGT	GTA	TTA	AAT	TTT	CAC	ATT	ATA	ATT	CCA	AGA	AAA	GAC	ATC	TGT
AAA	TCC	CGG	GTA	GGA	GGT	GTA	TTA	AAT	TTT	TAC	ATT	ATA	ATT	CCA	AGA	GAA	GAC	ATC	TGT
AAA	TCC	CGG	GTA	GGA	GGT	GTA	TTC	CAT	TTT	TAC	ATT	ATA	ATT	CCA	AGA	GAA	GAC	ATC	CGT
AAA	TCC	CGG	GTA	GGA	GCT	GTA	TTC	AAT	TTA	AAC	ATT	ATA	ATT	CAA	CGA	GAA	GAC	ACC	CGT
AAA	TCC	CGG	GTA	GGA	GCT	GTA	TTC	AAT	TTT	AAC	ATT	ATA	ATT	CCA	AGA	GAA	GAC	ACC	CGT
AAA	TCC	CGG	GTA	GGA	GCT	GTA	TTC	CAT	TTT	CAC	ATT	ATA	ATT	CCA	AGA	GAA	GAC	ATC	CGT
Lys	Ser	Arg	Val	Gly	Ala	Val	Phe	His	Phe	His	Ile	Ile	Ile	Pro	Arg	Glu	Asp	Ile	Arg
AAT	TCT	TGG	TTA	CGA	GGT	GTC	TTA	TAT	TTA	TAC	ATG	ATC	CTT	CCC	AAA	AAA	AAC	ATT	TGT
Asn	Ser	Trp	Leu	Arg	Gly	Val	Leu	Tyr	Leu	Tyr	Met	Ile	Leu	Pro	Lys	Lys	Asn	Ile	Cys
		CAG						AAT		AAC				CAA	CGA			ACC	
		Gln						Asn		Asn				Gln	Arg			Thr	

species studied here, however, it is still a sister species to them. *Daiswa fargesii* is a distinct species, which differs from all other related species by the carnosely rounded free portion of connective tissue with the apex markedly notched. *Daiswa violacea* is a very distinctive and attractive species in having smaller dark green leaves with whitish-variegated veins above, dark purplish below. Despite this, the species differs from the related polymorphic *D. polyphylla* in many morphological characters. Both are very closely related in terms of the molecular sequence similarities (see Figs 1–3; Tables 4, 7).

As mentioned above, all available molecular data indicate that *Paris*, *Kinugasa* and *Daiswa* doubtless diverged from common ancestors of the Trilliaceae (Figs 2–4).

However, we should pay special attention to the peculiar position of *T. rivale* in the two trees constructed with the *matK* gene and ITS sequencing data, in that it diverged at the base of the trees. The close affinities between *Trillium* and these genera (especially *Paris*) have long been confirmed by various standpoints, including morphology (Gate 1917), embryology (Berg 1962b), karyology (Haga 1934; Sen 1975), palynology (Takahashi 1984), physical structure of nrDNA (Yakura *et al.* 1983), and molecular phylogeny (Kato *et al.* 1995b). Possibly because of several missing links between the ancestors and modern species we cannot precisely evaluate the phylogenetic positions of these different taxa based only upon the molecular data available at present.

Table 9 Matrix of *matK* codons with autapomorphic nucleotide positions (boldface characters) from 26 taxa of Trilliaceae

Taxa	Codon number																	
	19	31	48	53	61	71	72	81	85	101	115	122	129	166	202	209	242	258
<i>Trillium rivale</i>	AAC	TAC	GAA	GGG	TCT	ACT	CGA	TAT	GAT	AAT	GTG	CGG	GAA	CCC	AGT	ATT	GTT	GTC
<i>T. undulatum</i>	AAC	TAC	GAA	GTG	TCC	ACT	CGA	TAT	GAC	CAT	GTG	CGA	GAA	CCC	AAT	CTT	TTT	GCC
<i>T. govianianum</i>	AAT	TAC	GCA	GTG	TCC	ACT	CGA	TAC	GAC	AAT	GTG	CGA	GAA	CCC	AAT	ATT	GTT	GCC
<i>T. pusillum</i>	–	TAC	GAA	GTG	TCC	ACT	CGA	TAT	GAC	AAT	GCG	CGA	GAA	CCC	AAT	ATT	GTT	GCC
<i>T. ovatum</i>	AAC	TAC	GAA	GTG	TCC	ACT	CGA	TAT	GAC	AAT	GTG	CGA	GAA	CCC	AAT	ATT	GTT	GCC
<i>T. grandiflorum</i>	AAC	TAC	GAA	GTG	TCC	ACT	CGA	TAT	GAC	AAT	GTG	CGA	GAA	CCC	AAT	ATT	GTT	GCC
<i>T. rugelii</i>	AAC	TAC	GAA	GTG	TCC	ACT	CGA	TAT	GAC	AAT	GTG	CGA	GAA	CCC	AAT	ATT	GTT	GCC
<i>T. erectum</i>	AAC	TAC	GAA	GTG	TCC	ACT	CAA	TAT	GAC	AAT	GTG	CGA	GAA	CCC	AAT	ATT	GTT	GCC
<i>T. camschatcense</i>	AAC	TAC	GAA	GTG	TCC	ACT	CGA	TAT	GAC	AAT	GTG	CGA	GAA	CCC	AAT	ATT	GTT	GCC
<i>T. lancifolium</i>	AAC	TAC	GAA	GTG	TCC	ACT	CGA	TAT	GAC	AAT	GTG	CGA	GAA	CCC	AAT	ATT	GTT	GCC
<i>T. recurvatum</i>	AAC	TAC	GAA	GTG	TCC	ACT	CGA	TAT	GAC	AAT	GTG	CGA	GAA	CCC	AAT	ATT	GTT	GCC
<i>T. sessile</i>	AAC	TAC	GAA	GTG	TCC	ACT	CGA	TAT	GAC	AAT	GTG	CGA	GAA	CCC	AAT	ATT	GTT	GCC
<i>T. chloropetalum</i>	AAC	TAC	GAA	GTG	TCC	ACT	CGA	TAT	GAC	AAT	GTG	CGA	GAA	CCC	AAT	ATT	GTT	GCC
<i>T. maculatum</i>	AAC	TAC	GAA	GTG	TCC	ACT	CGA	TAT	GAC	AAT	GTG	CGA	GAA	CCC	AAT	ATT	GTT	GCC
<i>T. decipiens</i>	AAC	TAC	GAA	GTG	TCC	ACT	CGA	TAT	GAC	AAT	GTG	CGA	GAA	CCC	AAT	ATT	GTT	GCC
<i>T. reliquum</i>	AAC	TAC	GAA	GTG	TCC	ACT	CGA	TAT	GAC	AAT	GTG	CGA	GAA	CCC	AAT	ATT	GTT	GCC
<i>T. discolor</i>	AAC	TAC	GAA	GTG	TCC	ACT	CGA	TAT	GAC	AAT	GTG	CGA	GAA	CCC	AAT	ATT	GTT	GCC
<i>T. petiolatum</i>	AAC	TAC	GAA	GTG	TCC	ACT	CGA	TAT	GAC	AAT	GTG	CGA	GAA	CCC	AAT	ATT	GTT	GCC
<i>Daiswa fargesii</i>	AAC	TAC	GAA	GTG	TCC	ATT	CGA	TAT	GAC	AAT	GTG	CGA	GAA	CCC	AAT	ATT	GTT	GCC
<i>D. polyphylla</i>	AAC	TAC	GAA	GTG	TCC	ACT	CGA	TAT	GAC	AAT	GTG	CGA	GAA	CCC	AAT	ATT	GTT	GCC
<i>D. thibetica</i>	AAC	TAC	GAA	GTG	TCC	ACT	CGA	TAT	GAC	AAT	GTG	CGA	GAA	CCC	AAT	ATT	GTT	GCC
<i>D. violacea</i>	AAC	TAT	GAA	GTG	TCC	ACT	CGA	TAT	GAC	AAT	GTG	CGA	GAA	CCC	AAT	ATT	GTT	GCC
<i>Kinugasa japonica</i>	AAC	TAC	GAA	GTG	TCC	ACT	CGA	TAT	GAC	AAT	GTG	CGA	AAA	CCC	AAT	ATT	GTT	GCC
<i>Paris incompleta</i>	AAC	TAC	GAA	GTG	TCC	ACT	CGA	TAT	GAC	AAT	GTG	CGA	GAA	CCC	AAT	ATT	GTT	GCC
<i>P. tetraphylla</i>	AAC	TAC	GAA	GTG	TCC	ACT	CGA	TAT	GAC	AAT	GTG	CGA	GAA	CCC	AAT	ATT	GTT	GCC
<i>P. verticillata</i>	AAC	TAC	GAA	GTG	TCC	ACT	CGA	TAT	GAC	AAT	GTG	CGA	GAA	CCA	AAT	ATT	GTT	GCC
Codon with amino acid [†]	AAC	TAC	GAA	GGG	TCT	ACT	CGA	TAT	GAT	AAT	GTG	CGG	GAA	CCC	AGT	ATT	GTT	GTC
	Asn	Tyr	Glu	Gly	Ser	Thr	Arg	Tyr	Asp	Asn	Val	Arg	Glu	Pro	Ser	Ile	Val	Val
	AAT	TAT	GCA	GTG	TCC	ATT	CAA	TAC	GAC	CAT	GCG	CGA	AAA	CCA	AAT	CTT	TTT	GCC
	Asn	Tyr	Ala	Val	Ser	Ile	Gln	Tyr	Asp	His	Ala	Arg	Lys	Pro	Asn	Leu	Phe	Ala

* Denotes the stop codon. [†] Boldface amino acids are non-synonymous substitutions.

Nucleotide substitutions in the *rbcL* and *matK* genes and the ITS region of *nrDNA*

A comparison of average species pairwise sequence divergences in the two chloroplast genes and the ITS region (Table 3) indicates that the ITS has much higher rates of nucleotide substitutions than the two chloroplast genes. The *rbcL* has much lower substitution rates than the *matK*, suggesting high functional constraint in the *rbcL* gene (Steele & Vilgalys 1994; Liang & Hilu 1996). Distinguishing autapomorphic, synapomorphic and homoplasious substitutions in the two chloroplast genes and ITS region should enable comparisons of the quality of phylogenetic information yielded from these regions

(Table 3). The percentage of phylogenetically informative sites (the sites where substitutions are shared by two or more taxa) among the variable sites is much more similar for the *matK* and ITS than for the *rbcL*. The percentage of synapomorphic sites among informative sites is highest in the *matK* region (71.74%), and lowest in the ITS region (40.71%).

Therefore, the *matK*, which has evolved moderately among the three regions, provides the best synapomorphic information and should be a useful region for phylogenetic studies at lower taxonomical levels (Soltis *et al.* 1996; Hilu & Liang 1997; Sang *et al.* 1997). In spite of its higher homoplasious substitutions (Table 3), ITS is also a relatively good marker to resolve phylogenetic

length (1608 b.p.) of the *matK* genes sequenced (Tables 8, 9), and then reconstructed the amino acid trees based upon the *matK* nucleotide base substitution data (Fig. 5).

In light of all available information concerning habitat radiations, morphological as well as life history characteristics (Samejima & Samejima 1987; Ohara 1989; Kawano *et al.* 1992; Kawano 1994; Kawano & Kato 1995; Case & Case 1997), karyology, genome constitutions and speciation (Bailey 1951, 1954; Haga & Kurabayashi 1954; Kurabayashi 1958; Dyer 1964a,b,c), palynology (Takahashi 1982, 1983, 1984), molecular systematic analyses (Kato *et al.* 1995a,b; Kazempour Osaloo *et al.*, 1999) and amino acid trees in this study rigorously reflect the affinities and evolutionary positions of taxa in the Trilliaceae.

Li *et al.* (1998) have very lately monographed the genus *Paris* (Trilliaceae) *sensu lato*, and they have again lumped together all three genera, *Daiswa*, *Kinugasa* and *Paris* (cf. also Li 1984, 1986; Li *et al.* 1988), but in order to obtain the more rigorous generic concept of the group here under consideration and to further elucidate the true phylogenetic relationships among taxa, additional critical studies are needed that cover all the currently known taxa, especially from China, although our results presented in this paper have shown clearly the phylogenetic status of representative taxa of the Trilliaceae.

Acknowledgements

The present series of studies was accomplished with the aid of many of our colleagues, to whom we wish to extend our gratitude: to Frederick H. Utech, Masashi Ohara, Noriaki Murakami, Hidetoshi Kato, Kazuhiko Hayashi, and Seiji Yoshida for their technical advice on sequencing and valuable discussions during the course of this study. Materials (*Daiswa fargesii*, *D. violacea*, *D. thibetica*, and *Paris incompleta*) were kindly supplied by Jin and Hiroko Murata, and Philip O. Ashbey of the Royal Botanic Garden, Edinburgh. The present study was financially supported by the following grants: Grant-in-Aids for Scientific Research on Priority Areas no. 04264102, International Scientific Research (Field Research) no. 01041055, no. 05041090; no. 08041143 to Shoichi Kawano (corresponding author) from Monbusho (Ministry of Education, Science, and Culture) of the Japanese Government.

References

Bailey P. C. (1951) A study of the chromosome morphology of some species of *Trillium*. *Bulletin of the Torrey Botany Club* **78**: 324–330.
 Bailey P. C. (1954) Further study of the chromosome morphology of some species of *Trillium*. *Bulletin of the Torrey Botany Club* **81**: 68–75.
 Baldwin B. G. (1992) Phylogenetic utility of the internal transcribed spacer of nuclear ribosomal DNA in plants: An example from the Compositae. *Molecular Phylogenetics and Evolution* **1**: 3–16.

Baldwin B. G., Sanderson M. J., Porter J. M., Wojciechowski M. F., Campbell C. S. & Donoghue M. J. (1995) The ITS region of nuclear ribosomal DNA: A valuable source of evidence on angiosperm phylogeny. *Annals of Missouri Botanic Garden* **82**: 247–277.
 Berg R. Y. (1959) Seed dispersal, morphology, and taxonomic position of *Scoliopus*, Liliaceae. *Skrifter Utgitt av det Norske Videnskaps-Academi i Oslo, Matematisk-Naturvidenskapelig Klasse* **4**: 1–56.
 Berg R. Y. (1962a) Morphology and taxonomic position of *Medeola*, Liliaceae. *Skrifter Utgitt av det Norske Videnskaps-Academi i Oslo, Matematisk-Naturvidenskapelig Klasse*. **3**: 1–55.
 Berg R. Y. (1962b) Contribution to the comparative embryology of the Liliaceae: *Scoliopus*, *Trillium*, *Paris*, and *Medeola*, Liliaceae. *Skrifter Utgitt av det Norske Videnskaps-Academi i Oslo, Matematisk-Naturvidenskapelig Klasse. Ny Serie* **4**: 1–64.
 Case Jr F. W. & Case R. B. (1997) *Trilliums*. Timber Press, Portland, OR.
 Chase M. W., Duvall M. R., Hills H. G. *et al.* (1995) Molecular phylogenetics of Liliaceae. In: *Monocotyledons: Systematics and Evolution*. (eds R. J. Rudall, P. J. Cribb, D. F. Cutler & C. J. Humphries) pp. 109–137. Royal Botanical Gardens, Kew.
 Dahlgren R. M. T., Clifford H. T. & Yeo P. F. (1985) *The Families of the Monocotyledones*. Springer-Verlag, Berlin.
 Davis J. I. (1995) A phylogenetic structure for the monocotyledons, as inferred from chloroplast DNA restriction site variation, and a comparison of measures of clade support. *Systematic Botany* **20**: 503–527.
 Doyle J. J. & Doyle J. L. (1987) A rapid DNA isolation procedure for small quantities of fresh leaf tissue. *Phytochemistry Bulletin* **19**: 11–15.
 Dyer A. F. (1964a) Heterochromatin in American and Japanese species of *Trillium*. I. Fusion of chromocentres and distribution of H-segments. *Cytologia* **29**: 155–170.
 Dyer A. F. (1964b) Heterochromatin in American and Japanese species of *Trillium*. II. The behavior of H-segments. *Cytologia* **29**: 171–190.
 Dyer A. F. (1964c) Heterochromatin in American and Japanese species of *Trillium*. III. Chiasma frequency and distribution and the effect on it of heterochromatin. *Cytologia* **29**: 263–279.
 Felsenstein J. (1985) Confidence limits on phylogenies: An approach using the bootstrap. *Evolution* **39**: 783–791.
 Felsenstein J. (1995) PHYLIP (Phylogeny Inference Package). Version 3.5c. University of Washington, Seattle.
 Fitch W. M. (1971) Toward defining the course of evolution: minimum change for a specific tree topology. *Systematic Zoology* **20**: 406–416.
 Fitch W. M. (1977) On the problem of discovering the most parsimonious tree. *American Naturalist* **111**: 223–257.
 Fukuda I. (1990) Chromosome differentiation among North American and Japanese *Trillium* species. In: *The Population Biology of Genes and Molecules* (eds J. F. Crow & N. Takahata) pp. 139–150. Baifukan Ltd., Tokyo.
 Gates R. R. (1917) A systematic study of the North American genus *Trillium*, its variability, its relation to *Paris* and *Medeola*. *Annals of the Missouri Botanical Garden* **4**: 43–93.
 Goldblatt P. (1995) The status of R. Dahlgren's order Liliales and Melanthiales. In: *Monocotyledons: Systematics and Evolution* (eds R. J. Rudall, P. J. Cribb, D. F. Cutler & C. J. Humphries) pp. 181–200. Royal Botanical Gardens, Kew.

- Haga T. (1934) The comparative morphology of the chromosome complement in the tribe Parideae. *Journal of Faculty of Science, Hokkaido University, Series 5* 3: 1–32.
- Haga T. (1937) Chromosome complement of *Kinugasa japonica* with the special reference to its origin and behavior. *Cytologia* 8: 137–141.
- Haga T. & Kurabayashi M. (1954) Genome and polyploidy in the genus *Trillium*. V. Chromosomal variation in natural populations of *Trillium kantschaticum* Pall. *Memoires of the Faculty of Science, Kyushu University, Series E, Biology* 1: 159–185.
- Hamby R. K. & Zimmer E. A. (1992) Ribosomal RNA as a phylogenetic tool in plant systematics. In: *Molecular Systematics of Plants* (eds P. S. Soltis, D. E. Soltis & J. J. Doyle) pp. 50–91. Chapman and Hall, New York.
- Hara H. (1969) Variation in *Paris polyphylla* Smith, with reference to other Asiatic species. *Journal of the Faculty of Science, University of Tokyo, Section 3* 10: 141–180.
- Hilu K. W. & Liang H. (1997) The *matK* gene: sequence variation and application in plant systematics. *American Journal of Botany* 84: 830–839.
- Howe C. J., Fearnley I. M., Walter J. E., Dyer T. A., Gray J. C. (1985) Nucleotide sequences of the genes for the alpha, beta, and epsilon subunits of wheat chloroplast ATP synthase. *Plant Molecular Biology* 4: 333–345.
- Hutchinson J. (1973) *The Family of Flowering Plants*, 3rd ed. Oxford Clarendon Press, Oxford.
- Johnson L. A. & Soltis D. E. (1994) *matK* DNA sequences and phylogenetic reconstruction in Saxifragaceae s. str. *Systematic Botany* 19: 143–156.
- Johnson L. A. & Soltis D. E. (1995) Phylogenetic inference in Saxifragaceae sensu stricto and Gilia (Polemoniaceae) using *matK* sequences. *Annals of the Missouri Botanical Garden* 82: 149–175.
- Kato H., Kawano S., Terauchi R., Ohara M. & Utech F. H. (1995a) Evolutionary biology of *Trillium* and related genera (Trilliaceae) I. Restriction site mapping and variation of chloroplast DNA and its systematic implications. *Plant Species Biology* 10: 17–29.
- Kato H., Terauchi R., Utech F. H. & Kawano S. (1995b) Molecular systematics of the Trilliaceae sensu lato as inferred from *rbcl* sequence data. *Molecular Phylogenetics and Evolution* 4: 184–193.
- Kawano S. (1994) *World Trillium: Life History and Evolution*. *World Plant Monograph Series* 1: 1–96 (in Japanese).
- Kawano S. & Kato H. (1995) Evolutionary biology of *Trillium* and related genera (Trilliaceae) II. Cladistic analyses on gross morphological characters, and phylogeny and evolution of the genus *Trillium*. *Plant Species Biology* 10: 169–183.
- Kawano S., Ohara M. & Utech F. H. (1992) Life history studies on the genus *Trillium* (Liliaceae) VI. Life history characteristics of three western North American species and their evolutionary-ecological implications. *Plant Species Biology* 7: 21–36.
- Kazempour Osaloo S., Utech F. H., Ohara M. & Kawano S. (1999) Molecular systematics of Trilliaceae I. Phylogenetic analyses of *Trillium* using *matK* gene sequences. *Journal of Plant Research* 112: 35–49.
- Kim K.-J. & Jansen R. K. (1994) Comparisons of phylogenetic hypotheses among different data sets in dwarf dandelions (*Krigia*, Asteraceae): Additional information from internal transcribed spacer sequences of nuclear ribosomal DNA. *Plant Systematics and Evolution* 190: 157–185.
- Kimura M. (1981) Estimation of evolutionary distances between homologous nucleotide sequences. *Proceedings of the National Academy of Sciences, USA* 78: 454–458.
- Knaak C., Hamby R. K., Arnold M. L., Lelance M. D., Chapman R. L. & Zimmer E. A. (1990) Ribosomal DNA variation and its use in plant biosystematics. In: *Biological Approaches and Evolutionary Trends in Plants* (ed. S. Kawano) pp. 135–158. Academic Press, London.
- Kubitzki K., Rudall P. J. & Chase M. C. (1998) Systematics and evolution. In: *The Families and Genera of Vascular Plants* (ed. K. Kubitzki) pp. 23–33. Springer-Verlag, Berlin.
- Kurabayashi M. (1958) Evolution and variation in Japanese species of *Trillium*. *Evolution* 12: 286–310.
- Li H. (1984) The phylogeny of the genus *Paris* L. *Acta Botanica Yunnanica* 6: 351–362.
- Li H. (1986) A study on the taxonomy of the genus *Paris* L. *Bulletin of Botanical Research* 6: 109–144.
- Li H. (ed.) (1998) *The Genus Paris* (Trilliaceae). Science Press, Beijing.
- Li H., Gu Z. & Na H. (1988) Cytogeographic study of the genus *Paris* L. *Acta Phytotaxonomica Sinica* 26: 1–10.
- Li H. & Noltie H. J. (1997) Miscellaneous notes on the genus *Paris*. *Edinburgh Journal of Botany* 54: 351–353.
- Liang H. & Hilu K. W. (1996) Application of the *matK* gene sequences to grass systematics. *Canadian Journal of Botany* 74: 125–134.
- Mitchell B. (1987) *Paris*-part I. *Plantsman* 9: 81–89.
- Mitchell B. (1988) *Paris*-part 2, *Daiswa*. *Plantsman* 10: 167–190.
- Miyamoto J., Kurita S. & Gu Zhijian & Li Hen[gl. (1992) C-banding patterns in eighteen taxa of the genus *Paris* sensu Li. *Liliaceae*. *Cytologia* 57: 181–194.
- Moon E., Kao T. & Wu R. (1987) Sequence of the chloroplast encoded *atpB*-*atpE*-*trnM* gene clusters from rice. *Nucleic Acids Research* 15: 4358–4359.
- Ohara M. (1989) Life history evolution in the genus *Trillium*. *Plant Species Biology* 4: 1–28.
- Ooi K., Endo Y., Yokoyama J. & Murakami N. (1995) Useful primer designs to amplify DNA fragment of the plastid gene *matK* from angiosperm plants. *Journal of Japanese Botany* 70: 328–333.
- Ro K.-E. & McPherson B. A. (1997) Molecular phylogeny of the *Aquilegia* group (Ranunculaceae) based on internal transcribed spacers and 5.8S nuclear ribosomal DNA. *Biochemical Systematics and Ecology* 25: 445–461.
- Saitou N. & Nei M. (1987) The neighbor-joining method: A new method for reconstructing phylogenetic trees. *Molecular Biology and Evolution* 4: 406–425.
- Samejima K. & Samejima J. (1987) *Trillium Genus*. Hokkaido University of Press, Sapporo.
- Sang T., Crawford D. J. & Stuessy T. F. (1995) Documentation of reticulate evolution in peonies (*Paeonia*) using internal transcribed spacer sequences of nuclear ribosomal DNA: Implications for biogeography and concerted evolution. *Proceedings of the National Academy of Sciences, USA* 92: 6813–6817.
- Sang T., Crawford D. J. & Stuessy T. F. (1997) Chloroplast DNA phylogeny, reticulate evolution, and biogeography of *Paeonia* (Paeoniaceae). *American Journal of Botany* 84: 1120–1136.
- Sen S. (1975) Cytotaxonomy of Liliales. *Feddes Repertorium* 86: 255–305.
- Shinwari Z. K., Kato H., Terauchi R. & Kawano S. (1994) Phylo-

- genetic relationships among genera in the Liliaceae–Asparagoideae–Polygonatae sensu lato inferred from *rbcL* gene sequence data. *Plant Systematics and Evolution* **192**: 263–277.
- Soltis D. E., Kuzoff R. K., Conti E., Gornall R. & Ferguson K. (1996) *matK* and *rbcL* gene sequence data indicate that *Saxifraga* (Saxifragaceae) is polyphyletic. *American Journal of Botany* **83**: 371–382.
- Soltis D. E., Sotis P. S., Clegg M. T. & Durbin M. (1990) *rbcL* sequence divergence and phylogenetic relationships in Saxifragaceae sensu lato. *Proceedings of the National Academy of Sciences, USA* **87**: 4640–4644.
- Steele K. P. & Vilgalys R. (1994) Phylogenetic analyses of Polemoniaceae using nucleotide sequences of the plastid gene *matK*. *Systematic Botany* **19**: 126–142.
- Stevenson D. W. & Loconte H. (1995) Cladistic analysis of monocot families. In: *Monocotyledons: Systematics and Evolution*. (eds R. J. Rudall, P. J. Cribb, D. F. Cutler & C. J. Humphries) pp. 541–578. Royal Botanical Gardens, Kew.
- Sugita M., Shinozaki K., Sugiura M. (1985) Tobacco chloroplast tRNA^{lys} (UUU) gene contains a 2.5 kilobase pairs intron: An open reading frame and a conserved boundary sequence in the intron. *Proceedings of the National Academy of Sciences, USA* **82**: 3557–3561.
- Swofford D. L. (1993) PAUP: Phylogenetic analysis using parsimony, version 3.1.1. Computer program distributed by the Illinois Natural History Survey, Champaign, IL.
- Takahashi M. (1982) Pollen morphology in North American species of *Trillium*. *American Journal of Botany* **69**: 1185–1195.
- Takahashi M. (1983) Pollen morphology in Asiatic species of *Trillium*. *Botany Magazine, Tokyo* **96**: 377–384.
- Takahashi M. (1984) Pollen morphology in *Paris* and its related genera. *Botany Magazine, Tokyo* **97**: 233–245.
- Takaiwa F., Oono K. & Sugiura M. (1985) Nucleotide sequence of the 17S–25S spacer region from rice rDNA. *Plant Molecular Biology* **4**: 355–364.
- Takhtajan A. (1980) Outline of the classification of flowering plants. *The Botanical Review* **46**: 225–359.
- Takhtajan A. (1983) A revision of *Daiswa* (Trilliaceae). *Brittonia* **35**: 255–270.
- Takhtajan A. (1987) *Systema magnoliophytorum* (Sistema magnoliofitov). Leninopoli Oficina Editoria 'NAUKA' Sectio Leninopolitana MCMLXXXVII, Moscow (in Russian).
- Takhtajan A. (1991) *Evolutionary Trends in Flowering Plants*. Columbia University of Press, New York.
- Takhtajan A. (1997) *Diversity and Classification of Flowering Plants*. Columbia University of Press, New York.
- Tamura M. N. (1995) A karyological review of the orders Asparagales and Liliales (Monocotyledonae). *Feddes Repertorium* **106**: 83–111.
- Tanaka N., Setoguchi H. & Murata J. (1997) Phylogeny of the family Hydrocharitaceae inferred from *rbcL* and *matK* gene sequence data. *Journal of Plant Research* **110**: 329–337.
- Tatewaki M. & Suto T. (1935) On the new genus *Kinugasa*. *Transactions of the Sapporo Natural History Society* **14**: 34–37.
- Terachi T., Ogiwara Y. & Tsunewaki K. (1987) The molecular basis of genetic diversity among cytoplasmic of *Triticum* and *Aegilops* VI. Complete nucleotide sequences of the *rbcL* genes encoding H- and L-type rubisco large subunits in common wheat and *Aegilops crassa* 4x. *Japanese Journal of Genetics* **62**: 375–388.
- Thorne R. F. (1983) Proposed new realignments in the angiosperms. *Nordic Journal of Botany* **3**: 85–117.
- Thorne R. F. (1992) Classification and geography of the flowering plants. *The Botanical Review* **58**: 225–348.
- Utech F. H. (1978) Floral vascular anatomy of *Medeola virginiana* L. (Liliaceae–Parideae=Trilliaceae) and tribal note. *Annals of Carnegie Museum* **47**: 13–28.
- Utech F. H. (1979) Floral vascular anatomy of *Scoliopus bigelovii* Torrey (Liliaceae–Parideae=Trilliaceae) and tribal note. *Annals of Carnegie Museum* **48**: 43–71.
- Utech F. H. (1992) Biology of *Scoliopus* (Liliaceae) I. Phytoecography and systematics. *Annals of the Missouri Botanical Garden* **79**: 126–142.
- White T. J., Bruns T., Lee S. & Taylor J. (1990) Amplification and direct sequencing of fungal ribosomal RNA genes for phylogenetics. In: *PCR Protocols: A Guide to Methods and Applications* (eds M. Innis, D. Gelfand, J. Sninsky & T. White) pp. 315–322. Academic Press, San Diego.
- Yakura K., Kato A. & Tanifuji S. (1983) Structural organization of ribosomal DNA in four *Trillium* species and *Paris verticillata*. *Plant Cell and Physiology* **24**: 1231–1240.
- Yasui Y. & Ohnishi O. (1998) Interspecific relationships in *Fagopyrum* (Polygonaceae) revealed by the nucleotide sequences of the *rbcL* and *accD* genes and their intergenic region. *American Journal of Botany* **85**: 1134–1142.
- Yokota Y., Kawata T., Iida Y., Kato A. & Tanifuji S. (1989) Nucleotide sequences of the 5.8S rRNA gene and internal transcribe spacer regions in carrot and broad bean ribosomal DNA. *Journal of Molecular Evolution* **29**: 294–301.